

**ROOF PITCH $\geq 10^\circ$
LOW / MEDIUM / HIGH WIND ZONE**

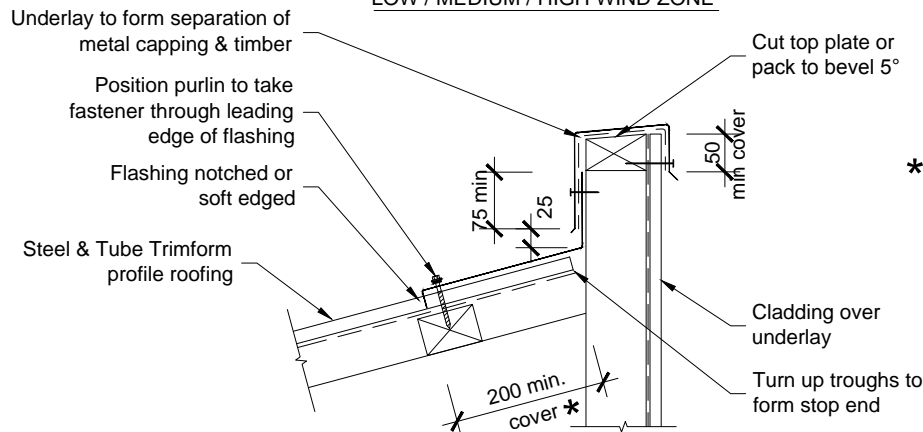

**ROOF PITCH $< 10^\circ$
LOW / MEDIUM / HIGH WIND ZONE**

* Alternatively 130 cover with addition of profiled foam sealer above purlin line

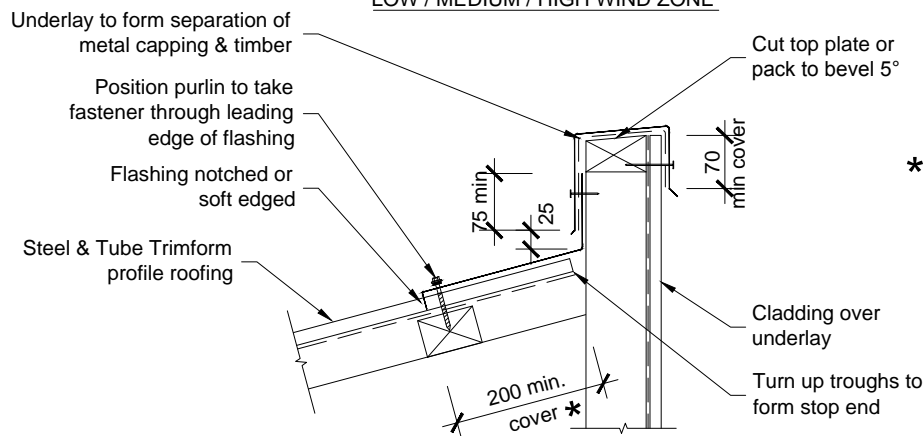

**ALL PITCHES
VERY HIGH WIND ZONE**

* Alternatively 130 cover with addition of profiled foam sealer above purlin line

ribb_trimform-parapet

**Rib Profile Head Parapet Flashing
Cross Section**

All dimensions in millimetres
Scale 1:10
16/01/12