



**SEISMIC
BRACING GUIDE
PARTITIONS & CEILINGS**

SEPTEMBER 2025



TRACKLOK®

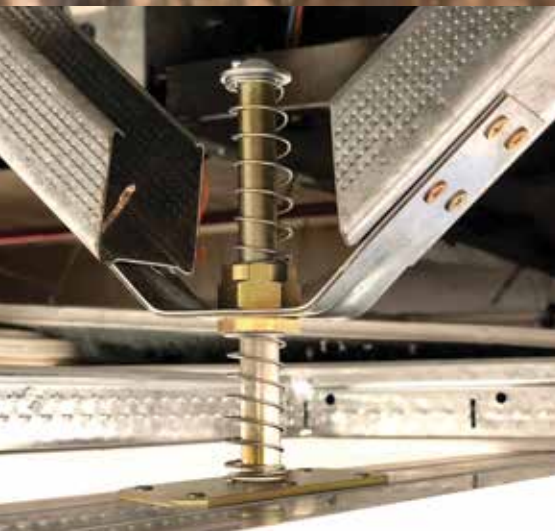

SEISMIC WALL BRACING



TRACKLOK®

Connect through the head track (min .75BMT Steel or 1.3mm Aluminium Section) utilising the connection bolt provided. Requires access to the head track and is suited to new installs.

CODE: SPT-10



TRACKLOK® PLUS

Connect through the head track (min .75BMT Steel or 1.3mm Aluminium Section) utilising minimum 10 gauge wafer tek screws. Connect to timber top plate (90 x 45mm SG8 Radiata Pine or Douglas Fir) using minimum 10 gauge 35mm wood screws.

CODE: SPT-10P



TRACKLOK® VERT

Utilises a vertical arm to avoid service clashes. Connect to the head track (min .75BMT Steel or 1.3mm Aluminium Section) with 10 gauge wafer tek screws or timber top plate (90 x 45mm SG8 Radiata Pine or Douglas Fir) with 10 gauge 35mm wood screws.

CODE: SPT-10V

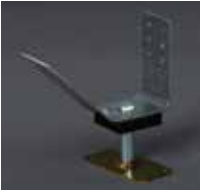

TRACKLOK® VERT PLUS

Utilises a vertical arm to avoid service clashes. Connect to the head track (min .75BMT Steel or 1.3mm Aluminium Section) with 10 gauge wafer tek screws or timber top plate (90 x 45mm SG8 Radiata Pine or Douglas Fir) with 10 gauge 35mm wood screws.

CODE: SPT-10VP

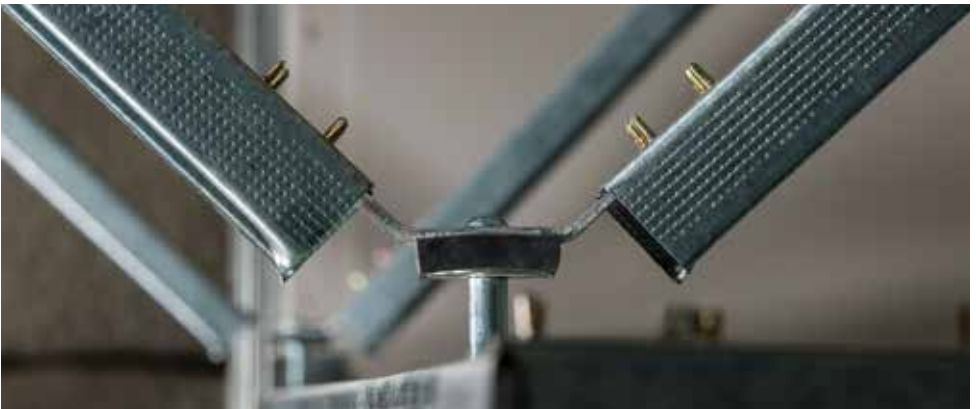

SEISMIC WALL BRACING

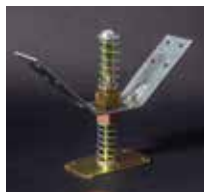

DEFLOK®

Allows for + / - 35mm of vertical deflection in a sealed unit. Connect to the head track (min .75BMT Steel or 1.3mm Aluminium Section) with 10 gauge wafer tek screws or timber top plate (90 x 45mm SG8 Radiata Pine or Douglas Fir) with 10 gauge 35mm wood screws.

CODE: DFK-10

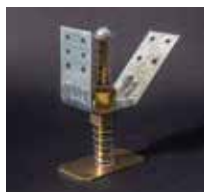

DEFLOK® VERT

Allows for + / - 35mm of vertical deflection in a sealed unit. Utilises a vertical arm to avoid service clashes. Connect to the head track (min .75BMT Steel or 1.3mm Aluminium Section) with 10 gauge wafer tek screws or timber top plate (90 x 45mm SG8 Radiata Pine or Douglas Fir) with 10 gauge 35mm wood screws.

CODE: DFK-10V



TRACKLOK® FLAT PLUS

Brace horizontally from one wall to another; allowing for unlimited vertical deflection, ultimate clash avoidance and accommodate impractical plenum heights. Connect to the head track (min .75BMT Steel or 1.3mm Aluminium Section) with 10 gauge wafer tek screws or timber top plate (90 x 45mm SG8 Radiata Pine or Douglas Fir) with 10 gauge 35mm wood screws. Vertical adjustability is built into each unit to accommodate for troffer lights and sprinkler pipes.

CODE: SPT-10FP

FEATURES AND BENEFITS

- Pre-engineered, extensively tested and internationally accredited
- Provides for separation of wall and ceiling systems
- Preserves ceiling system warranty
- Provides bracing arm flexibility from 30 – 60° (Steel stud braces should be designed by an engineer when brace arms are outside 30 – 60° range)
- Top connector plates included in every box
- See the plenum height chart and utilise steel stud for bracing arms
- Set out charts provide clear guidance on placement
- Use plans@tracklok.com or our online portal for a marked up plan
- Utilised in IL2, IL3 and IL4 buildings

COMPLIANCE

- NZBC B1 – Structure
- NZBC B2 – Durability
- AS/NZS 1170
- NZS 1170.5
- AS 1170.4
- AS/NZS 4219
- Contributes to NZBC F6 - Visibility in Escape Routes
- Contributes to NZBC D1 - Access Routes

SEISMIC ZONE MAP

HEIGHT	< 3M	< 6M	< 9M	9M +
ZONE 1	CHART 1	CHART 1	CHART 1	CHART 1
ZONE 2	CHART 1	CHART 1	CHART 2	CHART 2
ZONE 3	CHART 1	CHART 2	CHART 2	CHART 3

NOTES

1. Height (m) is to floor above partition.
2. Allows for 50mm of inter story drift.
3. For wall heights up to 3.0m.
4. For wall weights up to 40kg per m2.
5. For wall weights heavier than 40kg per m2 and for Importance Level 3 and 4 Buildings please contact plans@tracklok.com

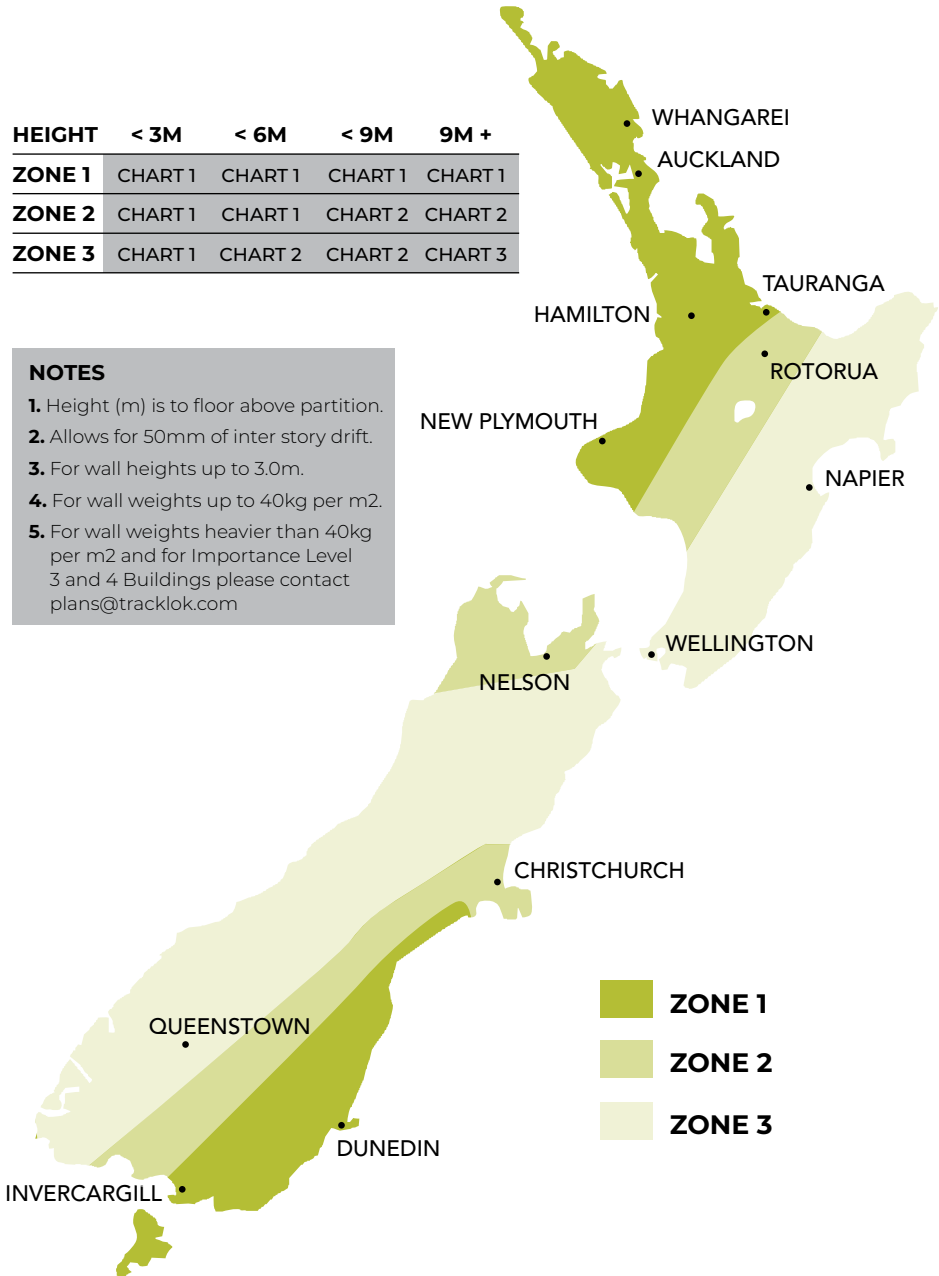

BRACING CHARTS

CHART ONE

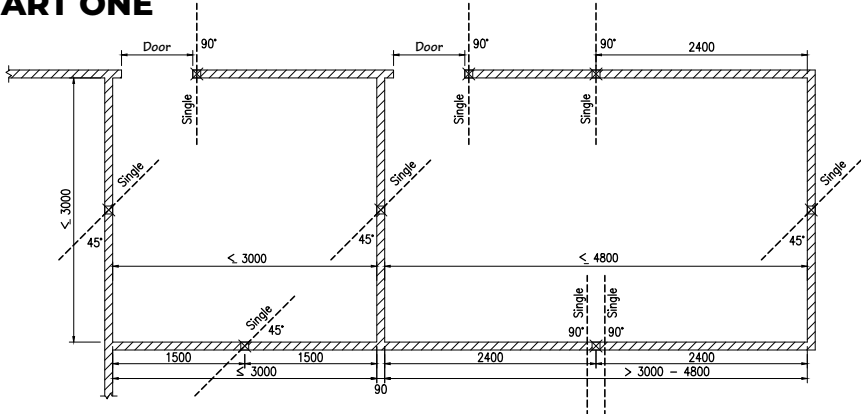

BRACING AROUND SMALL ROOMS

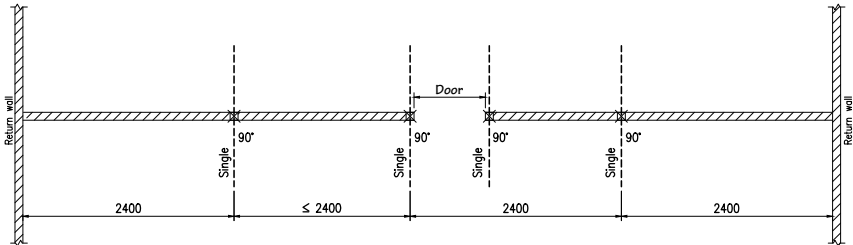

BRACING BETWEEN RETURN WALLS

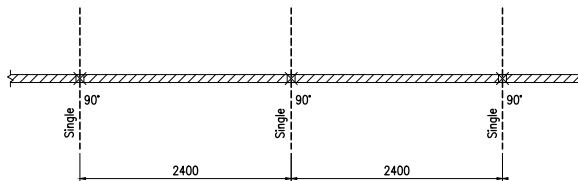

STRAIGHT WALLS WITH NO RETURN WALLS

NOTES

1. Height (m) is from lowest floor in building to floor above partition.
2. Spacings based on horizontal load $< 0.75 \text{ kN/m}$.
3. Allows for 50mm of inter story drift.
4. For wall heights up to 3.0m.
5. For wall weights up to 40kg per m².
6. Each dashed line represents one brace.

AUCKLAND all levels

WELLINGTON up to 3.0m above ground

CHRISTCHURCH up to 6.0m above ground

BRACING CHARTS

CHART TWO

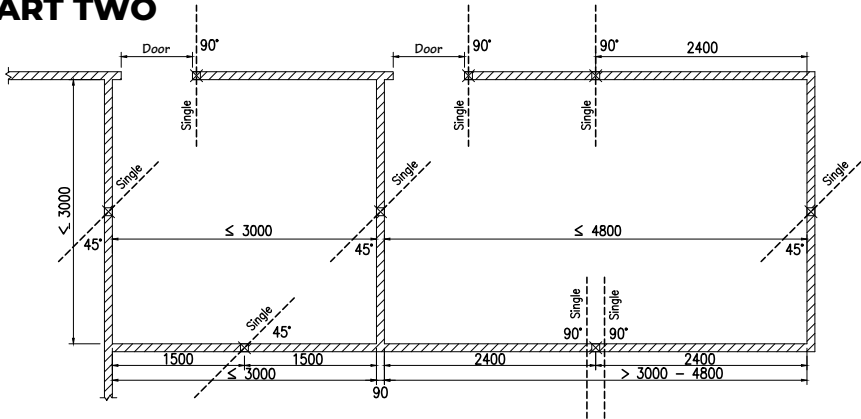

BRACING AROUND SMALL ROOMS

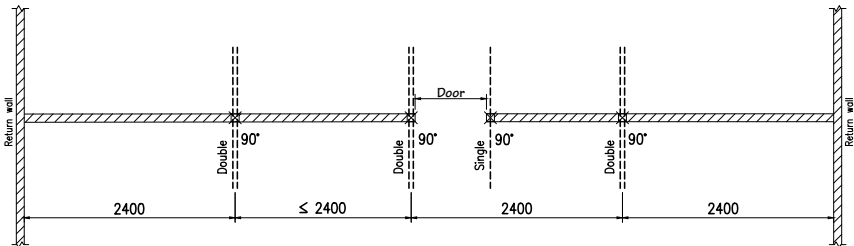

BRACING BETWEEN RETURN WALLS

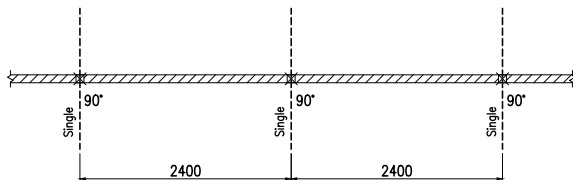

STRAIGHT WALLS WITH NO RETURN WALLS

NOTES

1. Height (m) is from lowest floor in building to floor above partition.
2. Spacings based on horizontal load $< 1.20 \text{ kN/m}$.
3. Allows for 50mm of inter story drift.
4. For wall heights up to 3.0m.
5. For wall weights up to 40kg per m².
6. Each dashed line represents one brace.

WELLINGTON from 3.0m to 9.0m above ground
CHRISTCHURCH above 6.0m from ground

BRACING CHARTS

CHART THREE

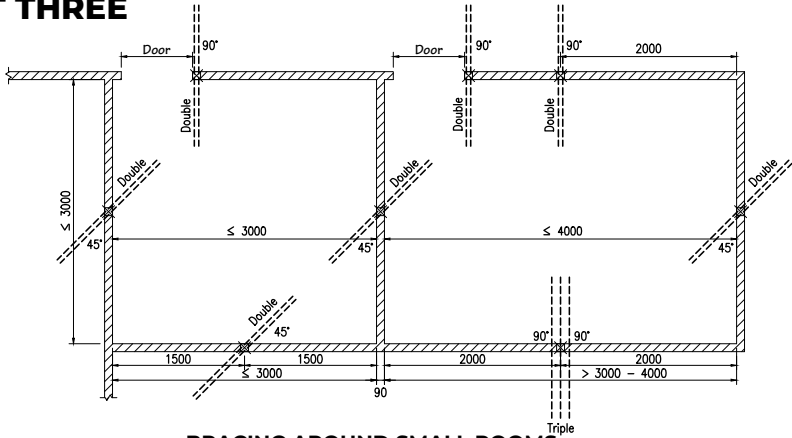

BRACING AROUND SMALL ROOMS

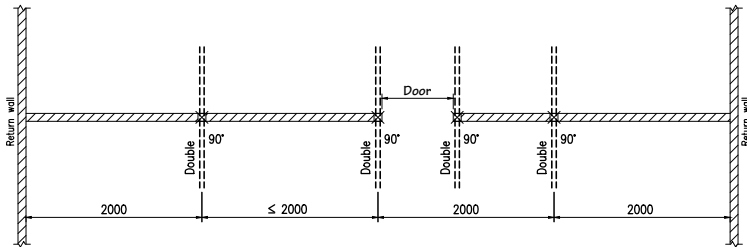

BRACING BETWEEN RETURN WALLS

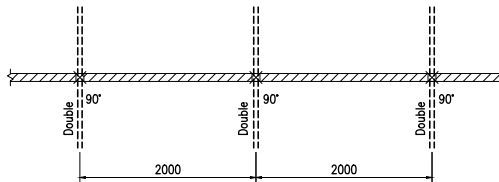

STRAIGHT WALLS WITH NO RETURN WALLS

NOTES

1. Height (m) is from lowest floor in building to floor above partition.
2. Spacings based on horizontal load $< 1.60 \text{ kN/m}$.
3. Allows for 50mm of inter story drift.
4. For wall heights up to 3.0m.
5. For wall weights up to 40kg per m².
6. Each dashed line represents one brace.

WELLINGTON above 9.0m from ground

TRACKLOK® FLAT

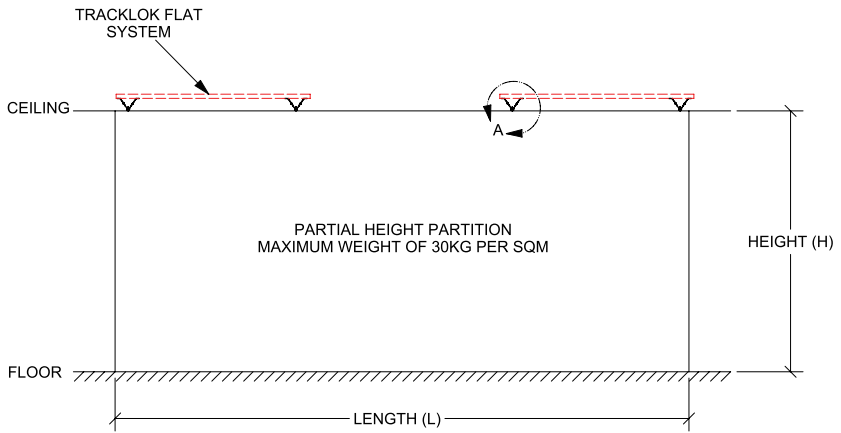
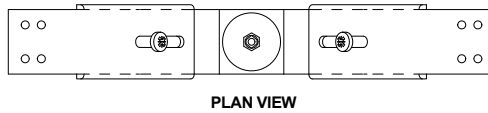
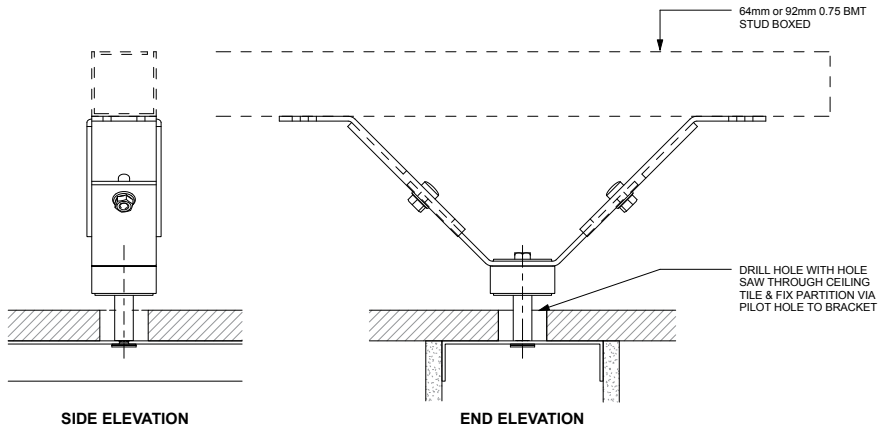

PARTITION ELEVATION

TRACKLOK® FLAT

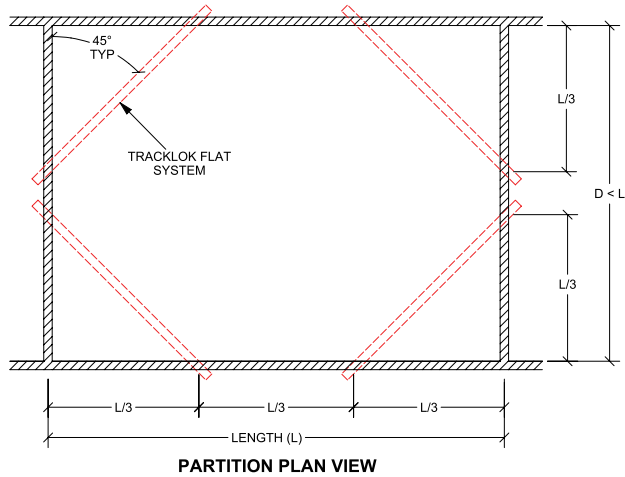

PERMISSIBLE PARTITION LENGTH (L) (MM)

HEIGHT MM	PARTITION HEADTRACK SIZE			
	64 X 0.75 BMT	64 X 1.15 BMT	92 X 0.75 BMT	92 X 1.15 BMT
2500	4800	6150	5550	7000
2750	4800	5590	5050	7000
3000	4630	5120	4630	7000
3250	4270	4730	4270	6710
3500	3960	4390	3960	6230
3750	3700	4100	3700	5820
4000	3470	3840	3470	545

NOTES

- Partition walls are to be internal and non-load bearing
- Structural engineer should confirm strength of partition studs and connections
- Partition walls to be lined both sides with 10mm(min) plasterboard to transfer shear loading
- Permissible partition length shall be taken as the lowest value of in Table 1 when bracing various headtrack sizes. For example when a 64x0.75BMT is braced to a 92x1.15BMT the permissible wall length is that of the 64x0.75BMT headtrack
- Based upon a maximum partition weight of 30kg per square metre
- Minimum yield strength of 270mpa and ultimate strength 330MPA required for generic steel studs
- All steel stud brace material must be boxed min .75BMT (see page 28 for detail)

SEISMIC CEILING BRACING

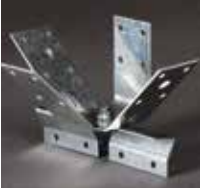

GRIDLOK®

Seismic bracing for two way and drywall suspended grid ceiling systems. For use with steel stud and seismic wire. Simple click fit and screw off process. Utilise minimum 10 gauge wafer tek screws.

CODE: GRD-10



GRIDLOK® PEAK FORM

Seismic bracing for two way and drywall suspended grid ceiling systems featuring a higher bulb. For use with steel stud and seismic wire. Simple click fit and screw off process. Utilise minimum 10 gauge wafer tek screws.

CODE: GRD-10P



GRIDLOK® FURRING CHANNEL

Seismic bracing for drywall suspended screw fix systems where connection to the furring channel is required. For use with steel stud and seismic wire. Simple click fit and screw off process. Utilise minimum 10 gauge wafer tek screws.

CODE: GRD-10F

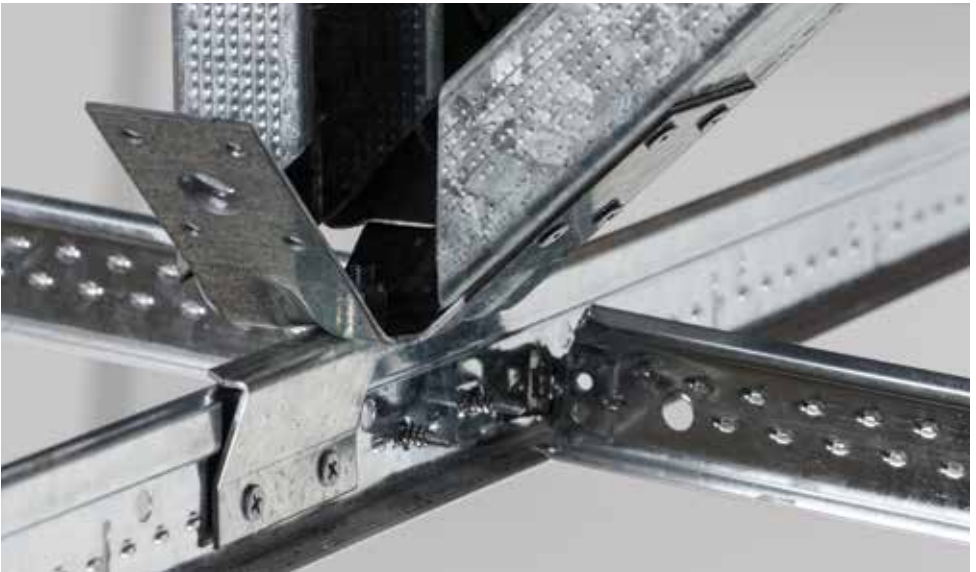

SEISMIC CEILING BRACING



GRIDLOK® TCR

Seismic bracing for drywall suspended screw fix systems where connection to the top cross rail (TCR) is required. For use with steel stud and seismic wire. Simple click fit and screw off process. Utilise minimum 10 gauge wafer tek screws.

CODE: GRD-10S



GRIDLOK® U-PROFILE

Seismic bracing for drywall suspended grid systems where connection to the U Profile is required. For use with steel stud and seismic wire. Simple click fit and screw off process. Utilise minimum 10 gauge wafer tek screws.

CODE: GRD-10U



GRIDLOK® C-CHANNEL

Seismic bracing for drywall suspended grid systems where connection to the C-Channel is required. For use with steel stud and seismic wire. Simple click fit and screw off process. Utilise minimum 10 gauge wafer tek screws.

CODE: GRD-10C

FEATURES AND BENEFITS

- Pre-engineered, extensively tested and internationally accredited
- Provides up to a maximum of 280kg/f
- Reduces install time to 15 minutes per brace
- Rotate unit through 360° for optimum bracing footprint
- Connection saddles designed for all ceiling systems
- Provides bracing arm flexibility from 30 – 60°
- Top connector plates included in every box
- See the plenum height chart and utilise steel stud for bracing arms
- Utilised in IL2, IL3 and IL4 buildings

COMPLIANCE

- NZBC B1 – Structure
- NZBC B2 – Durability
- AS/NZS 2785
- AS/NZS 1170
- NZS 1170.5
- AS 1170.4
- AS/NZS 4219
- Contributes to NZBC F6 - Visibility in Escape Routes
- Contributes to NZBC D1 - Access Routes

ISOMETRICS

GRIDLOK®

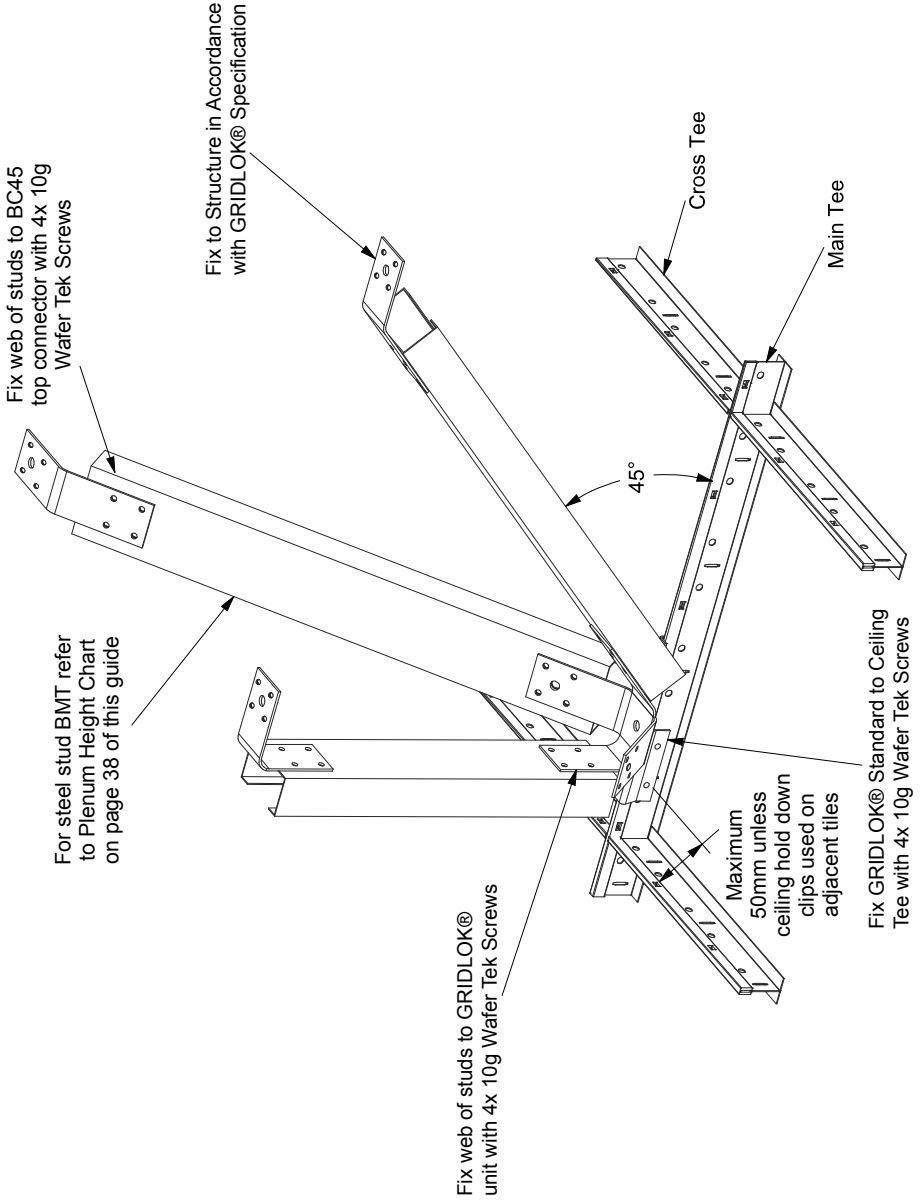

ISOMETRICS

GRIDLOK® PEAKFORM

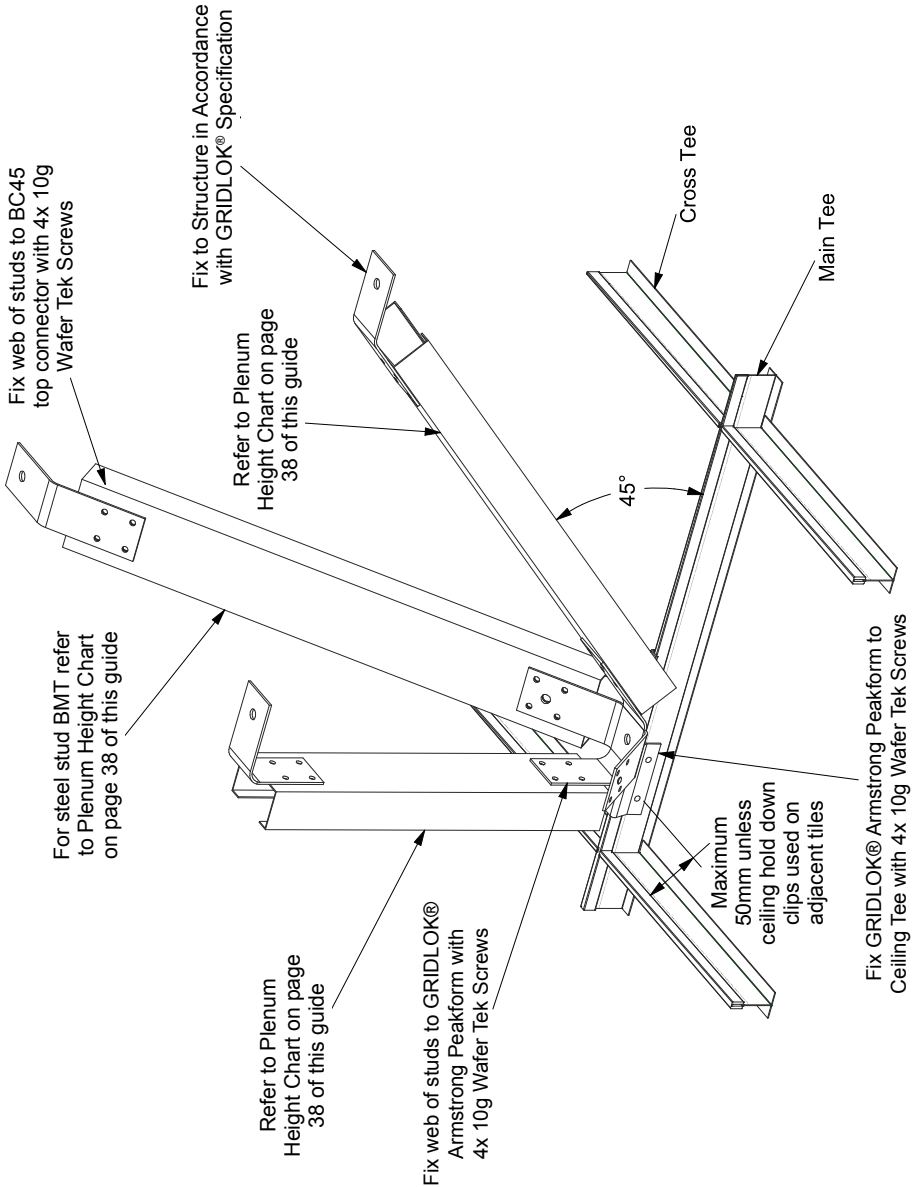

ISOMETRICS

GRIDLOK® FURRING CHANNEL

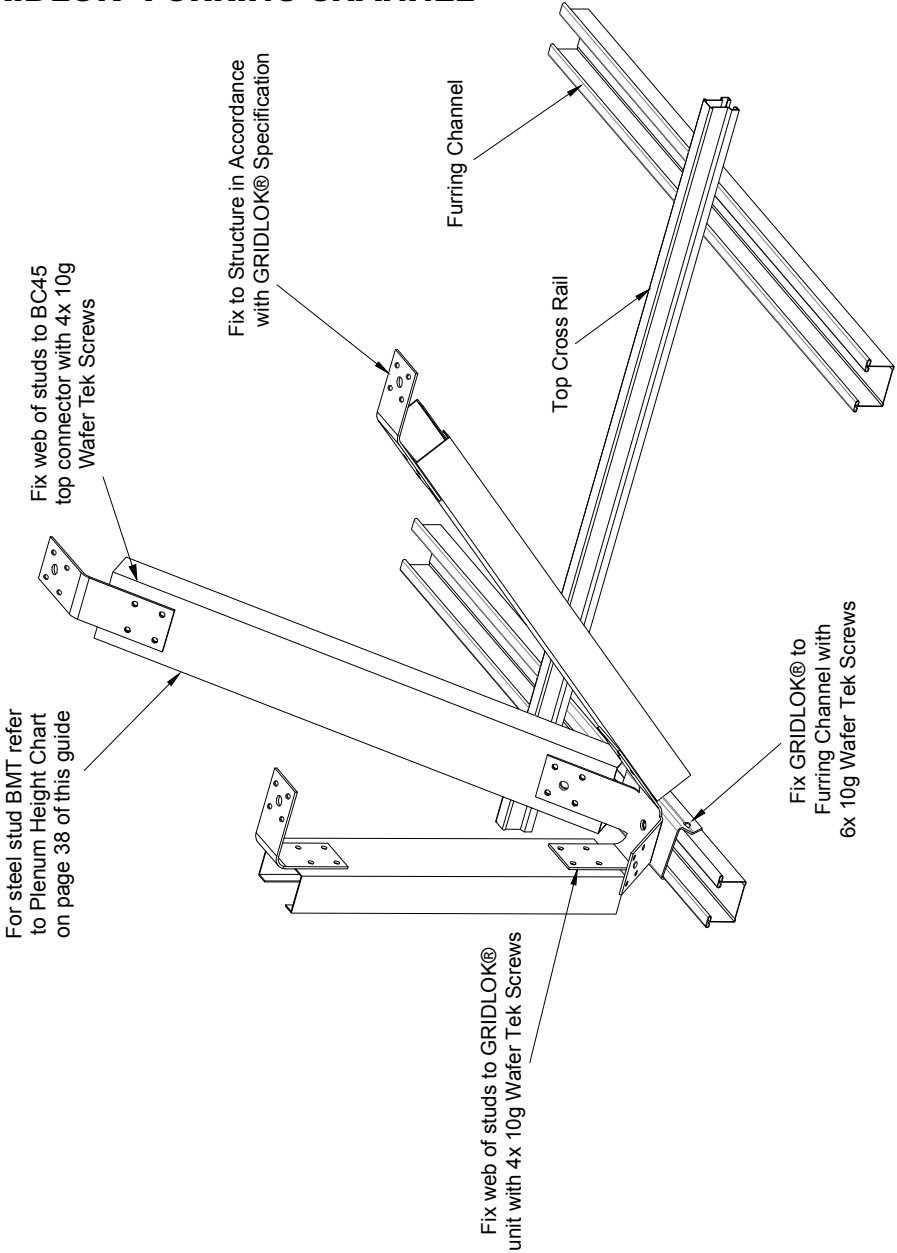

ISOMETRICS

GRIDLOK® TCR

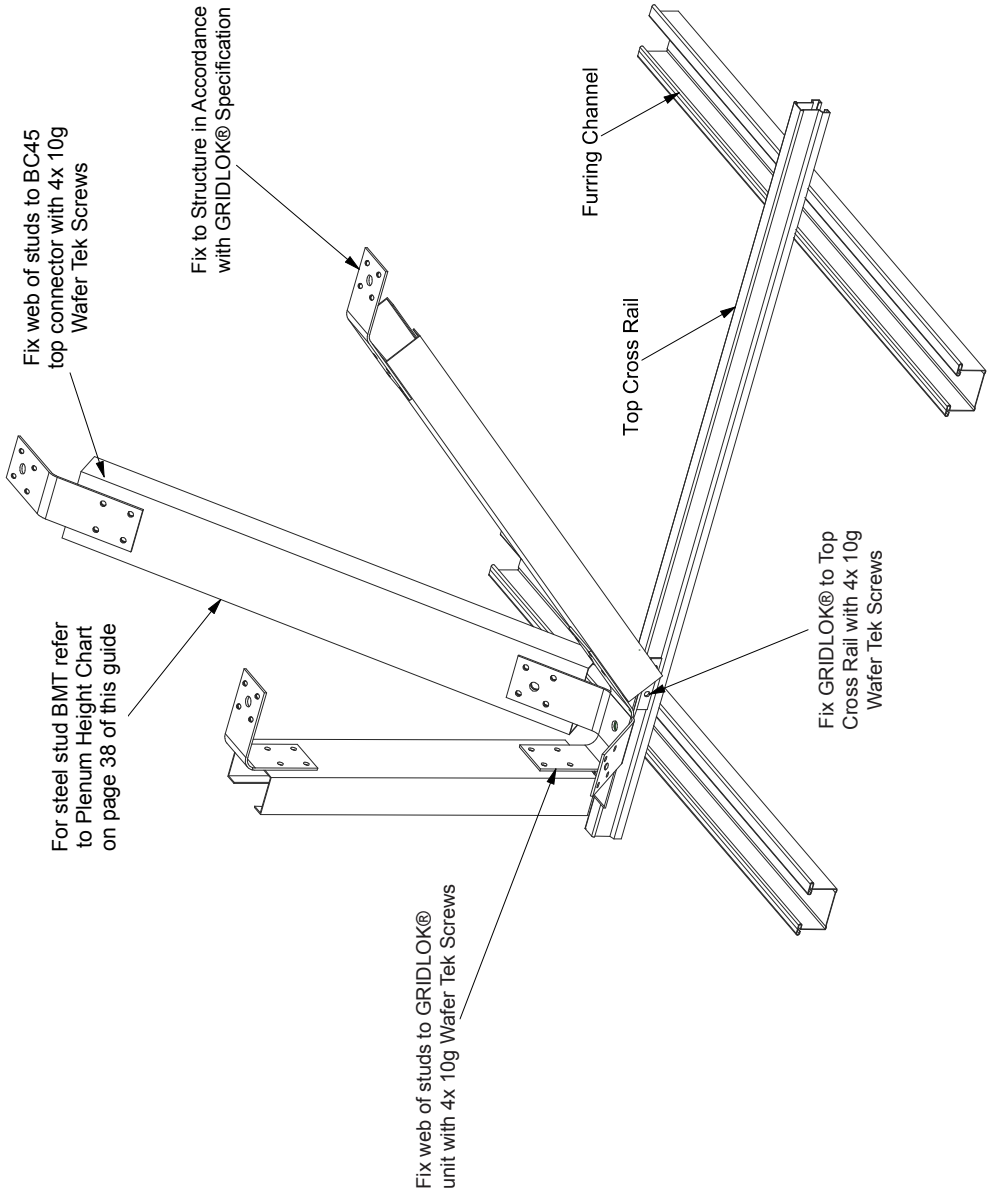

ISOMETRICS

GRIDLOK® U-PROFILE

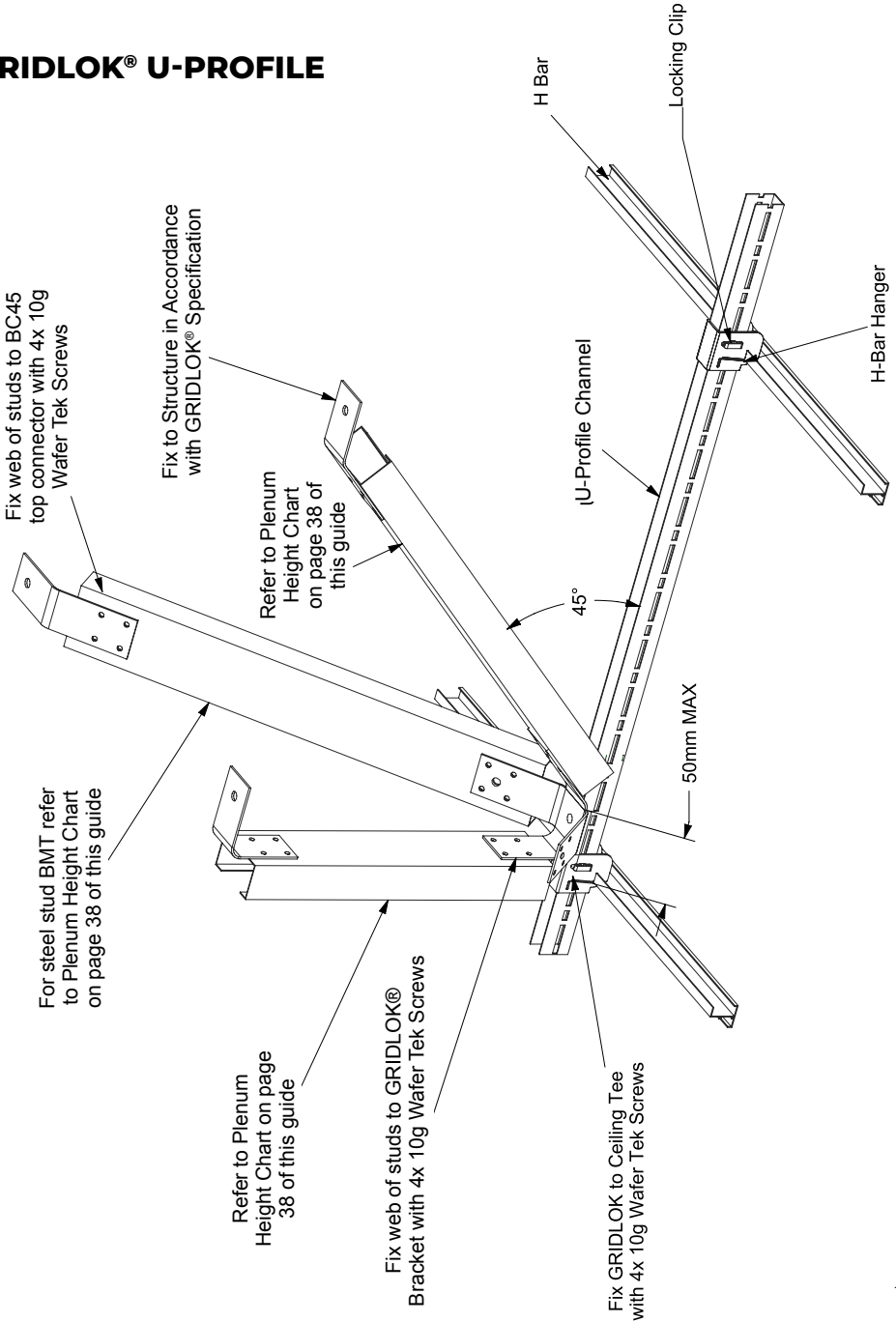

ISOMETRICS

GRIDLOK® C-CHANNEL

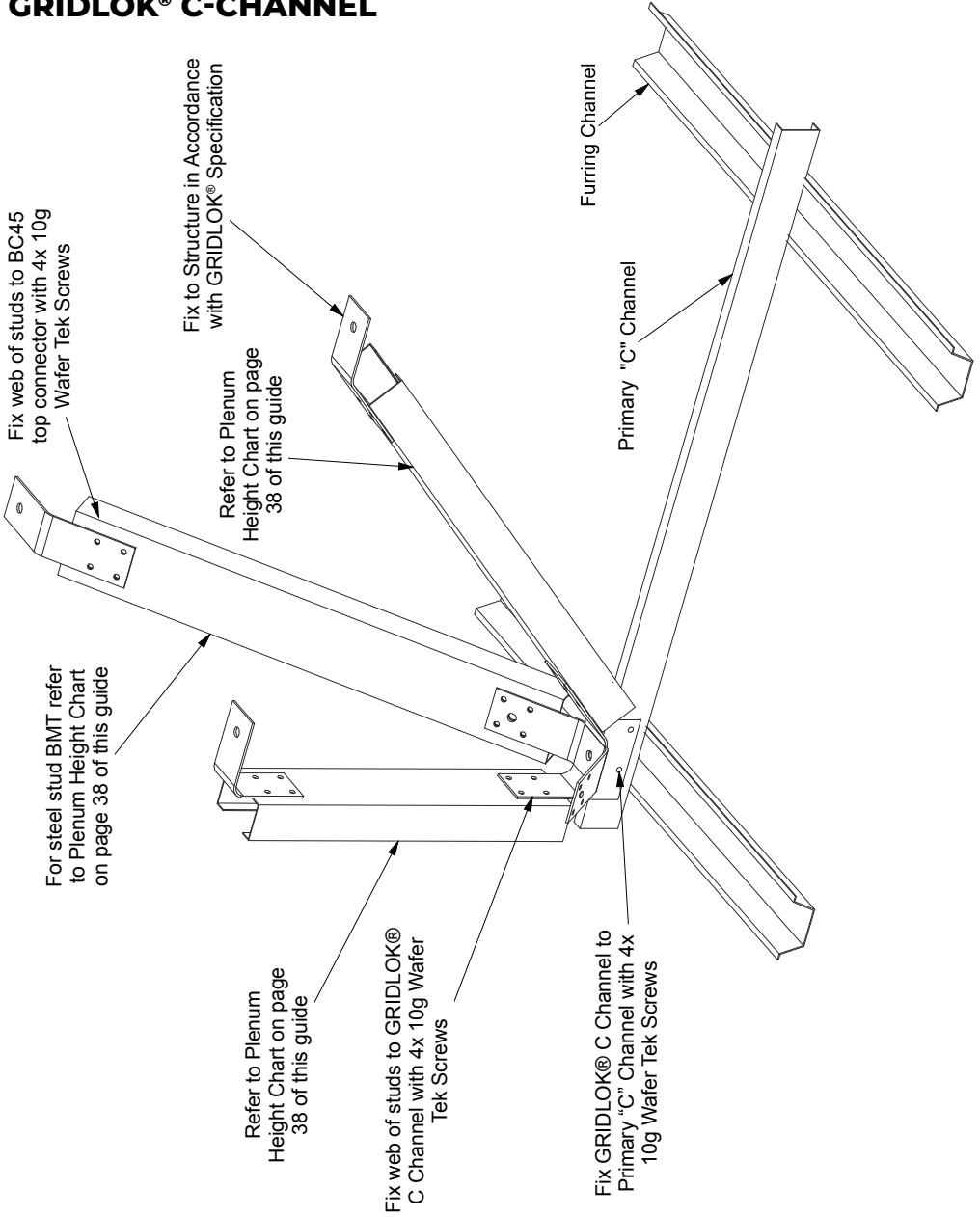

GRIDLOK® ZIP CLIP

For use with steel stud and Zip Clip seismic wire.

Fix to Structure in Accordance with GRIDLOK® Zip Clip Specification using M10 anchor bolts

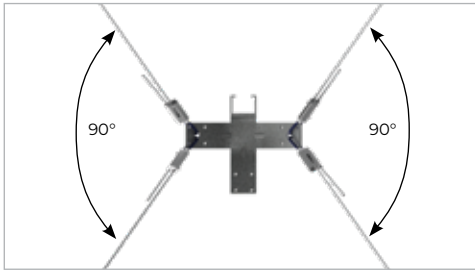
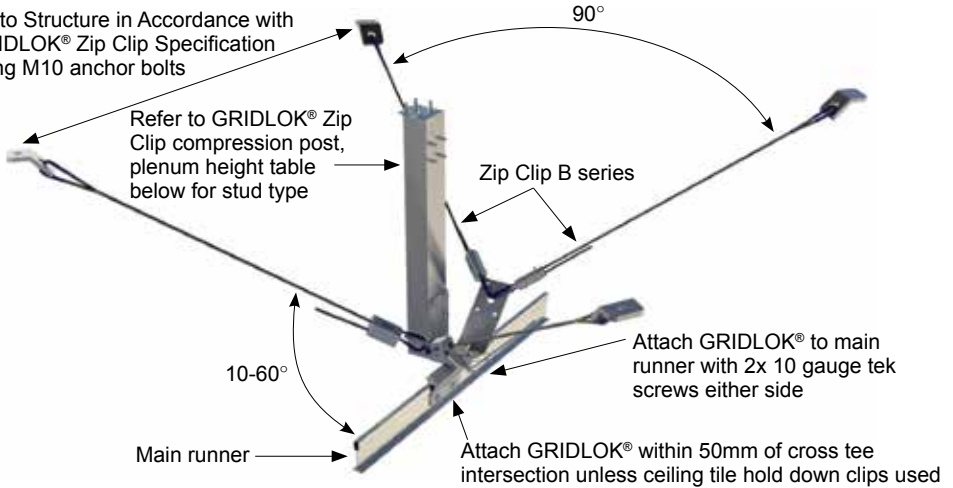

Figure 1

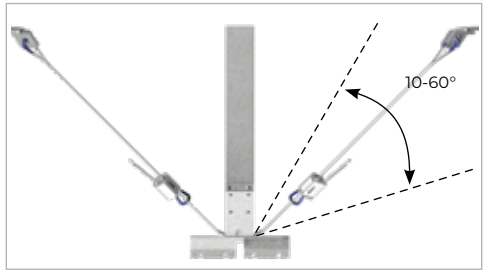

Figure 2

COMPRESSION POST TABLE

64 X 0.55BMT STUDS	92 X 0.75BMT STUDS	64 X 0.55BMT BOXED STUDS	92 X 0.75BMT BOXED STUDS	92 X 1.2BMT MAXI JAMB OR SIMILAR
280kgf/2.75kN UP TO 1800MM	280kgf/2.75kN UP TO 2600MM	280kgf/2.75kN UP TO 3500MM	280kgf/2.75kN UP TO 5000MM	280kgf/2.75kN UP TO 6000MM

GRIDLOK® ZIP CLIP

FEATURES AND BENEFITS

- Pre-engineered, extensively tested and internationally accredited. Provides up to a maximum of 280kg/f per brace. Reduces install time to 15 minutes per brace.
- Rotate unit through 360 degrees for optimum bracing footprint. Connection saddles designed for all ceiling systems.
- Top connector plates for compression post included in every box.

INSTALLATION

- Click on and screw GRIDLOK base unit to main runner with 10 gauge wafer tek screws. If attachment is more than 50mm from main and cross runner junction, ceiling tile hold down clips should be used on adjacent tiles.
- Screw vertical flange of GRIDLOK base unit to web of compression post selected using plenum height chart in table on page 17 with 10 gauge wafer tek screws

- Attach top of compression post to structure over using supplied BC 90 top connector as per pages 22 to 27 of the TRACKLOK Bracing Guide. Ensure fixing is through web of the compression post and compression post is no more than 1 in 6 (10 degrees) out of plumb.
- Attach Zip Clip Blue series seismic wires to structure over with Zip Clip supplied top connectors following manufacturers guidance. Ensure wire layout follows guidelines as per Figure 1 on page 17.
- Install 4 Zip Clip Blue series seismic wires to GRIDLOK base unit using 2 wires per 10mm hole in 45 degree flanges.
- Seismic wires should be at 90 degrees to each other, see Figure 1 on page 17.
- Seismic wires should be set between 10 and 60 degrees, see Figure 2 on page 17.
- Adjust Zip Clip Blue series seismic wires as per manufacturer's instructions.
- Utilised in IL2, IL3 and IL4 buildings.

COMPLIANCE

- NZBC B1 – Structure NZBC B2 – Durability AS/NZS 2785 AS/NZS 1170
- NZS 1170.5
- AS 1170.4
- AS/NZS 4219
- Contributes to NZBC F6 - Visibility in Escape Routes
- Contributes to NZBC D1 - Access Routes

ACCESSORIES

GAPLOK

On occasion, a partition wall or a glazing line placement may coincide with the main runner or nog of a two-way grid ceiling system. In this instance, there would be no way for a TRACKLOK® to pass through the grid, with the required clearance. GAPLOK has been carefully designed, developed and engineered to allow installers to accommodate TRACKLOK® bracing in these instances. GAPLOK provides for 316kgf of capacity.

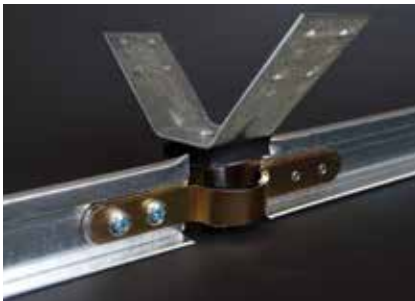
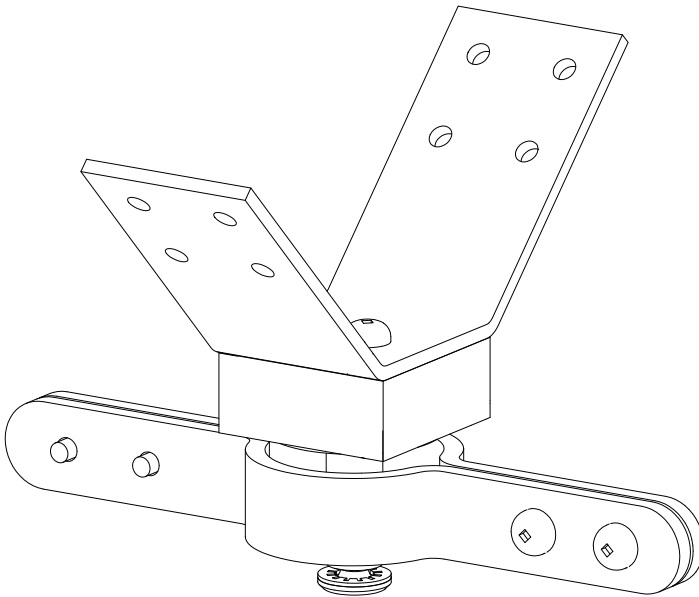

GAPLOK

Allows installers to take a 40mm section out of the grid. Clamp GAPLOK to either side of the remaining grid section to bridge the gap, reinstate the grid's structural integrity and allow the clearance required of the TRACKLOK® unit.

STOCK CODE: GGP-10

ACCESSORIES

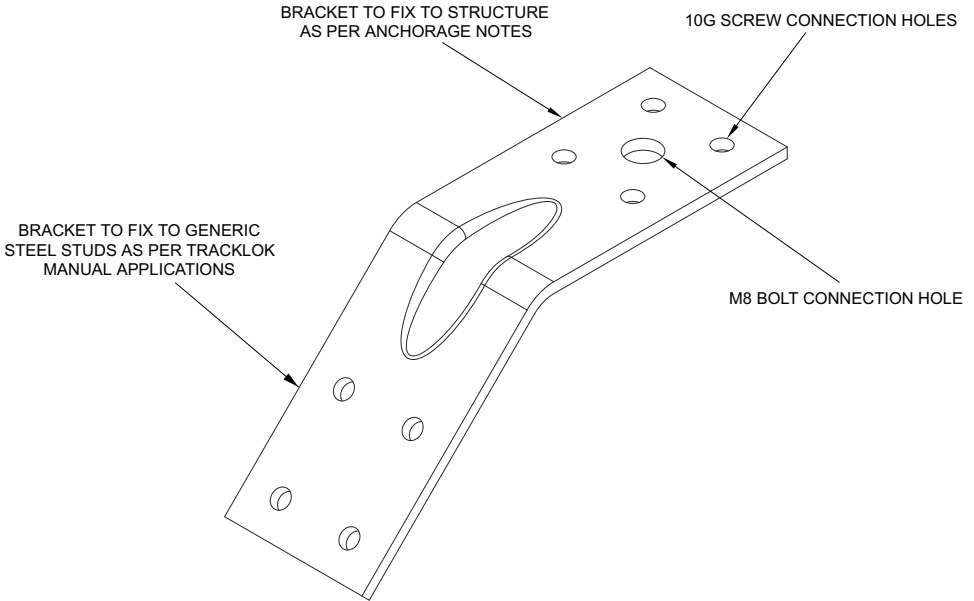

BULKHEAD & BRIDGING CONNECTOR 45

Designed and tested to provide a consistent and quantifiable connection capacity. Used in conjunction with steel stud to brace bulkheads. Our height vs centres chart provides install guidance. Also, used to assist in the bridging of services.

STOCK CODE: BC-45 (SOLD IN PAIRS)

STRUCTURE ANCHORAGE NOTES

CONCRETE:

- Stud anchor 50mm(min) embedment
- Screw anchor 55mm(min) embedment

STEEL:

- M8 Cl. 4.8 bolt/nut into 1.15BMT(min)
- 4x 10g wafer tek screws into 0.75BMT(min)

TIMBER:

- M8 x 75 coach screw full penetration
- M8 Cl. 4.8 bolt/nut with 20 x 20 x 1.5 washer
- 4x 10g x 35 woodscrews 30mm(min) penetration

NOTES

- Structural engineer should confirm loading into structure
- Consult TRACKLOK® manual for permissible applications
- Can be bent once in field between 30 – 60°

FOR FURTHER TOP CONNECTION DETAILS SEE OUR FULL ONLINE BRACING GUIDE VERSION

ACCESSORIES

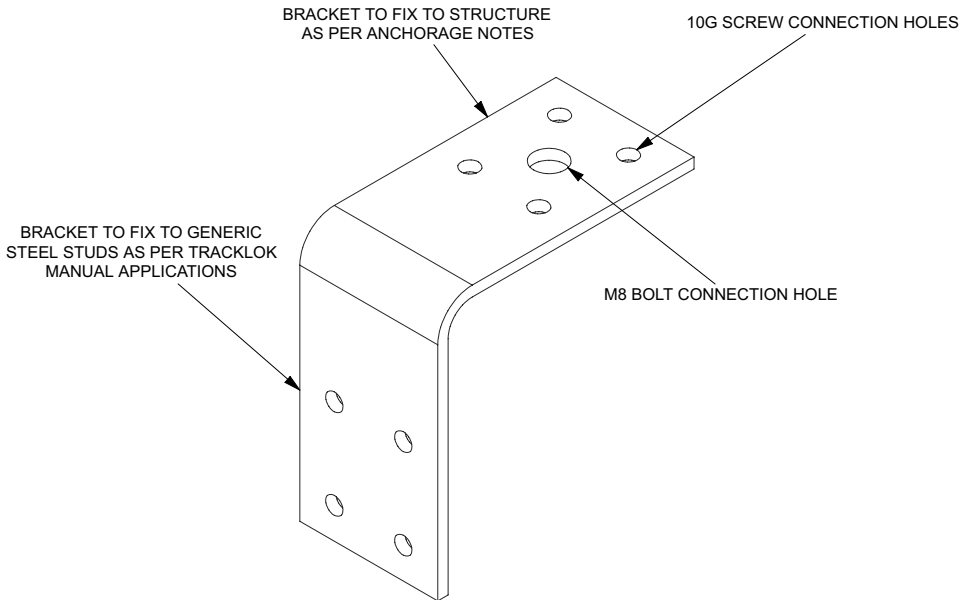

BRIDGING CONNECTOR 90

Designed and tested to provide a consistent and quantifiable connection capacity. Used in conjunction with steel stud to bridge purlins allowing parallel and perpendicular bracing connections.

STOCK CODE: BC-90 (SOLD IN PAIRS)

STRUCTURE ANCHORAGE NOTES

CONCRETE:

- Stud anchor 50mm(min) embedment
- Screw anchor 55mm(min) embedment

STEEL:

- M8 Cl. 4.8 bolt/nut into 1.15BMT(min)
- 4x 10g wafer tek screws into 0.75BMT(min)

TIMBER:

- M8 x 75 coach screw full penetration
- M8 Cl. 4.8 bolt/nut with 20 x 20 x 1.5 washer
- 4x 10g x 35 woodscrews 30mm(min) penetration

NOTES

- Structural engineer should confirm loading into structure
- Consult TRACKLOK® manual for permissible applications

FOR FURTHER TOP CONNECTION DETAILS SEE OUR FULL ONLINE BRACING GUIDE VERSION

TOP CONNECTION - CONCRETE

M8 STUD EXPANSION ANCHOR
OR SIMILAR SEISMICALLY APPROVED
ANCHOR INSTALL AS PER MANUFACTURER'S
SPECIFICATION

FOR STAHLTON RIB STRUCTURES
ENSURE CONCRETE EMBEDMENT IS
ACHIEVED BY USING LONGER ANCHORS

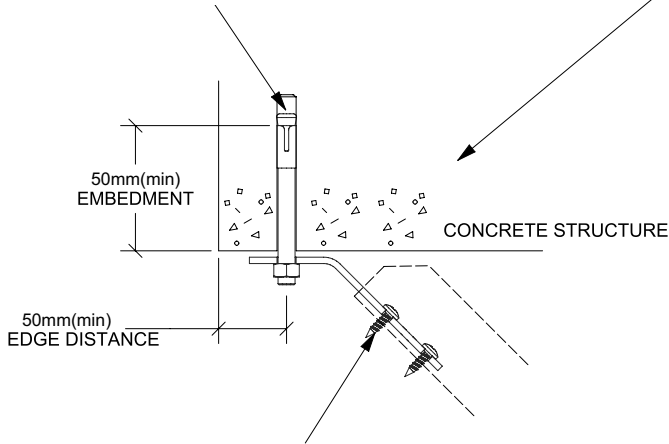

FIX STEEL STUD TO SUPPLIED BRACKET WITH
4x 10G WAFER TEK SCREWS (TRACKLOK®)
OR 4x 10G WAFER TEK SCREWS (GRIDLOK®)

FOR STAHLTON RIB STRUCTURES
ENSURE CONCRETE EMBEDMENT IS
ACHIEVED BY USING LONGER ANCHORS

M8 ANCHOR OR SIMILAR
SEISMICALLY APPROVED ANCHOR
INSTALL AS PER MANUFACTURER'S
SPECIFICATION

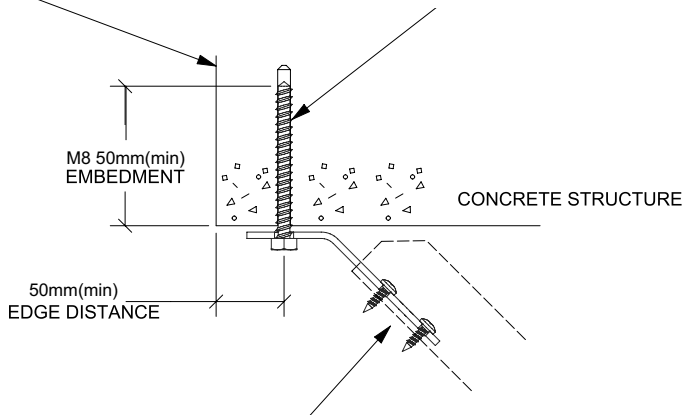

FIX STEEL STUD TO SUPPLIED BRACKET WITH
4x 10G WAFER TEK SCREWS (TRACKLOK®)
OR 4x 10G WAFER TEK SCREWS (GRIDLOK®)

TOP CONNECTION - COMFLOR

M8 ANCHOR OR SIMILAR
SEISMICALLY APPROVED ANCHOR
INSTALL AS PER MANUFACTURER'S
SPECIFICATION

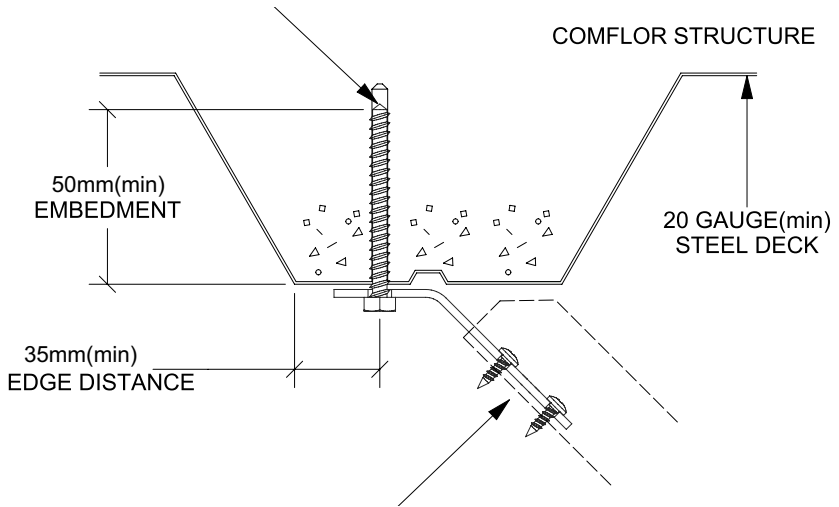

FIX STEEL STUD TO SUPPLIED BRACKET WITH
4x 10G WAFER TEK SCREWS (TRACKLOK®)
OR 4x 10G WAFER TEK SCREWS (GRIDLOK®)

TOP CONNECTION - STEEL

TEK SCREW FIXING

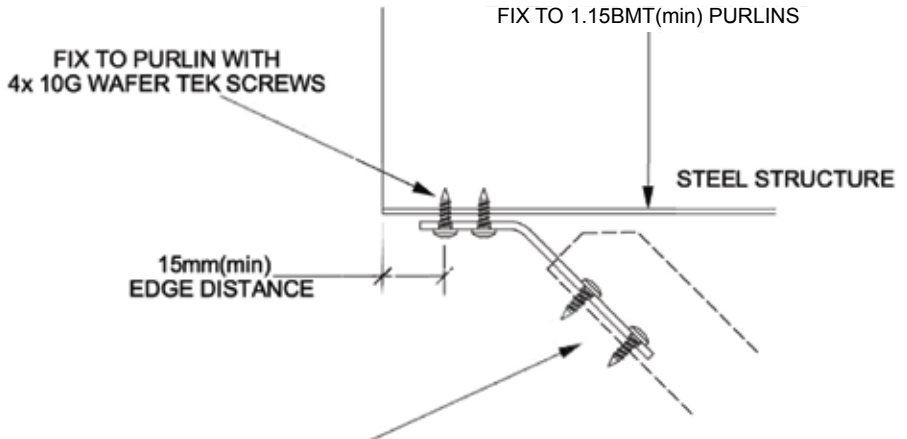

FIX STEEL STUD TO SUPPLIED BRACKET WITH
4x 10G WAFER TEK SCREWS (TRACKLOK®)
OR 4x 10G WAFER TEK SCREWS (GRIDLOK®)

BOLT FIXING

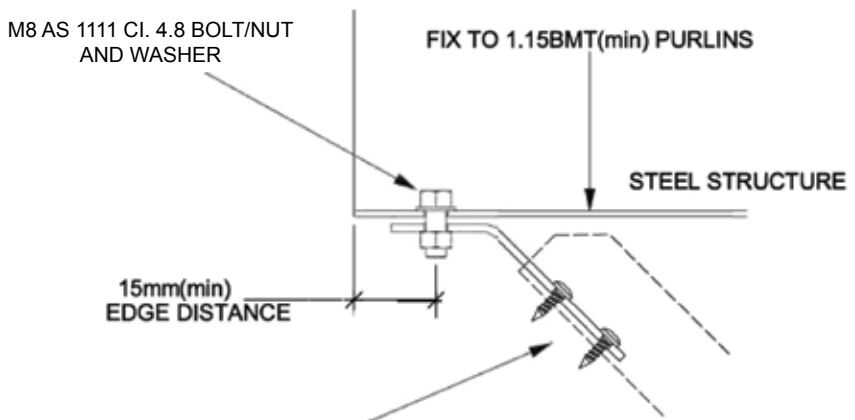

FIX STEEL STUD TO SUPPLIED BRACKET WITH
4x 10G WAFER TEK SCREWS (TRACKLOK®)
OR 4x 10G WAFER TEK SCREWS (GRIDLOK®)

TOP CONNECTION - PURLINS

TEK SCREW FIXING

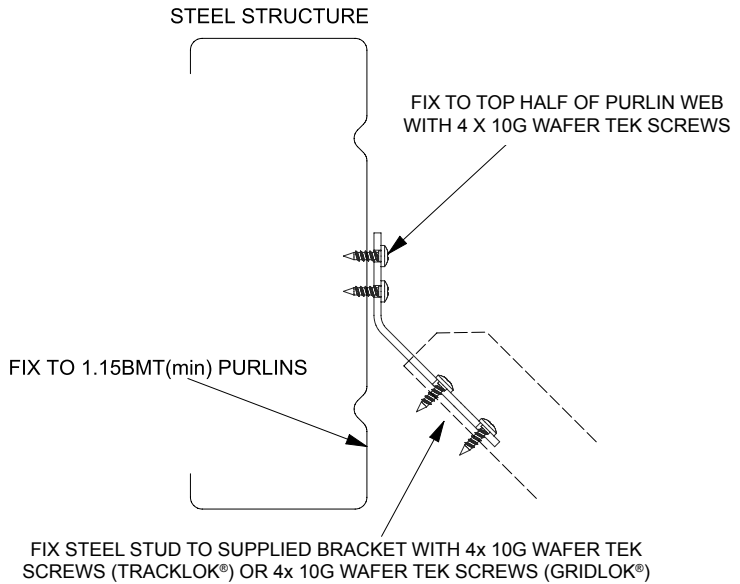

BOLT FIXING

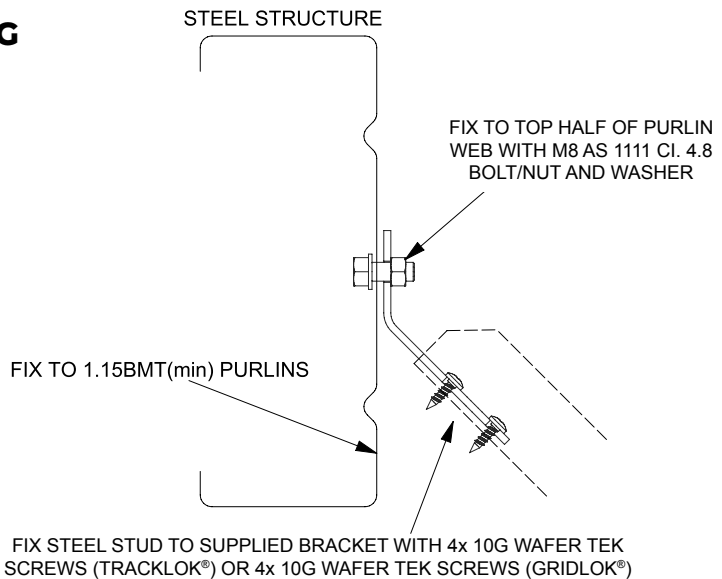

TOP CONNECTION - TIMBER

WOOD SCREW FIXING

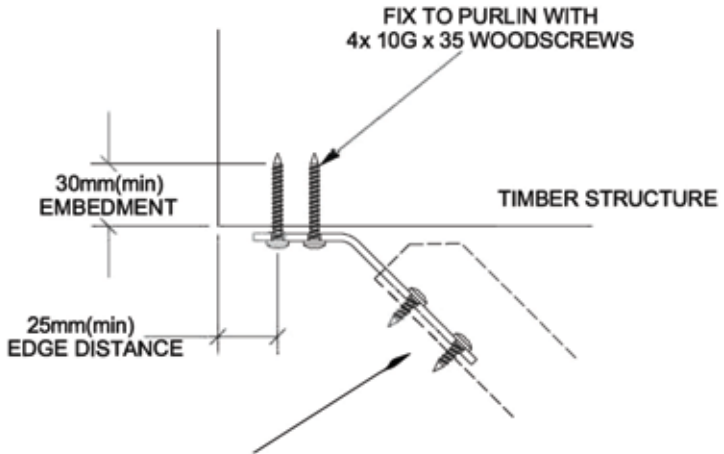

FIX STEEL STUD TO SUPPLIED BRACKET WITH 4x 10G WAFER TEK SCREWS (TRACKLOK®) OR 4x 10G WAFER TEK SCREWS (GRIDLOK®)

COACH SCREW FIXING

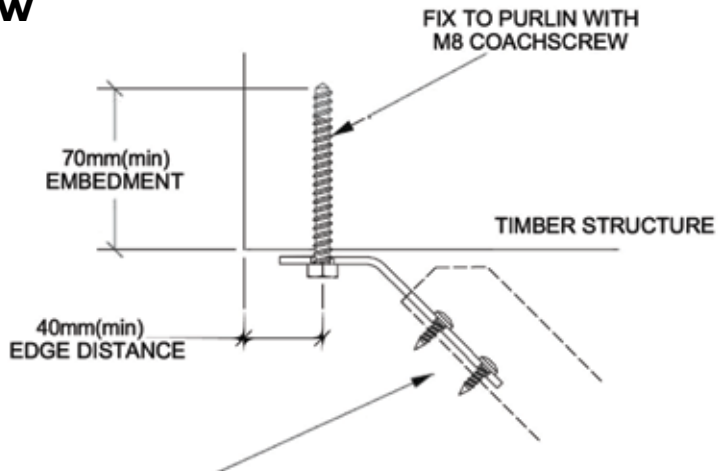

FIX STEEL STUD TO SUPPLIED BRACKET WITH 4x 10G WAFER TEK SCREWS (TRACKLOK®) OR 4x 10G WAFER TEK SCREWS (GRIDLOK®)

TOP CONNECTION - TIMBER

WOOD SCREW FIXING

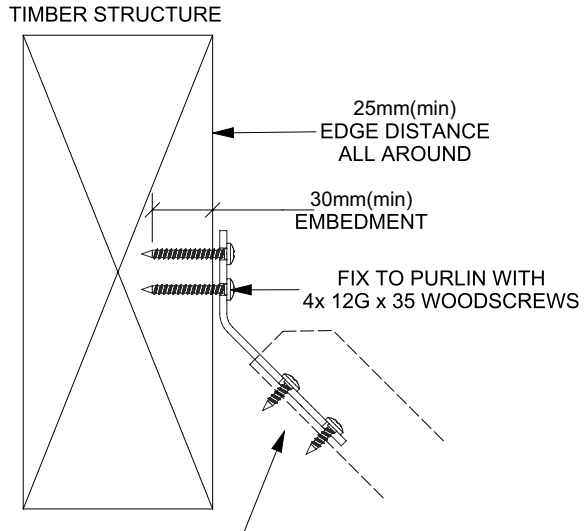

FIX STEEL STUD TO SUPPLIED BRACKET WITH 4x 10G WAFER TEK SCREWS (TRACKLOK®) OR 4x 10G WAFER TEK SCREWS (GRIDLOK®)

BOLT FIXING

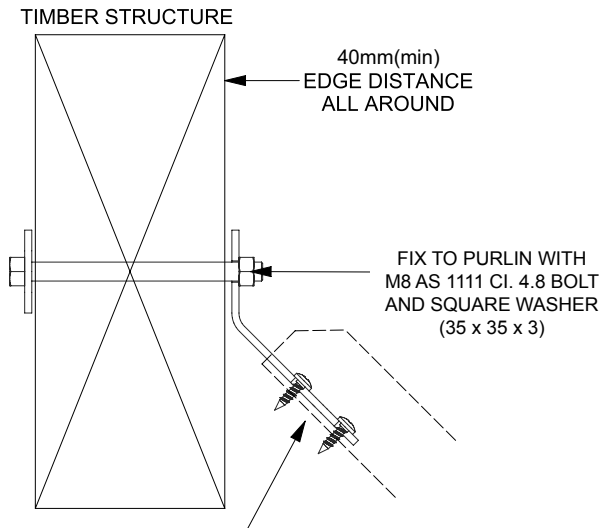

FIX STEEL STUD TO SUPPLIED BRACKET WITH 4x 10G WAFER TEK SCREWS (TRACKLOK®) OR 4x 10G WAFER TEK SCREWS (GRIDLOK®)

BRIDGING PURLINS

PARALLEL

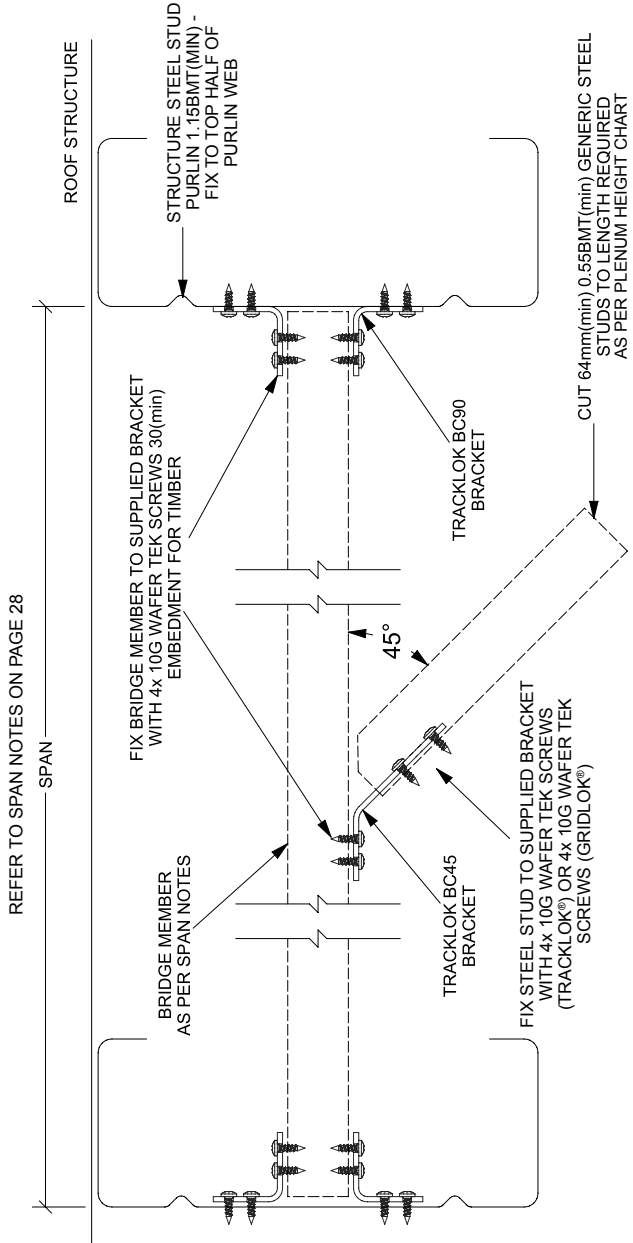

BRIDGING PURLINS

PERPENDICULAR

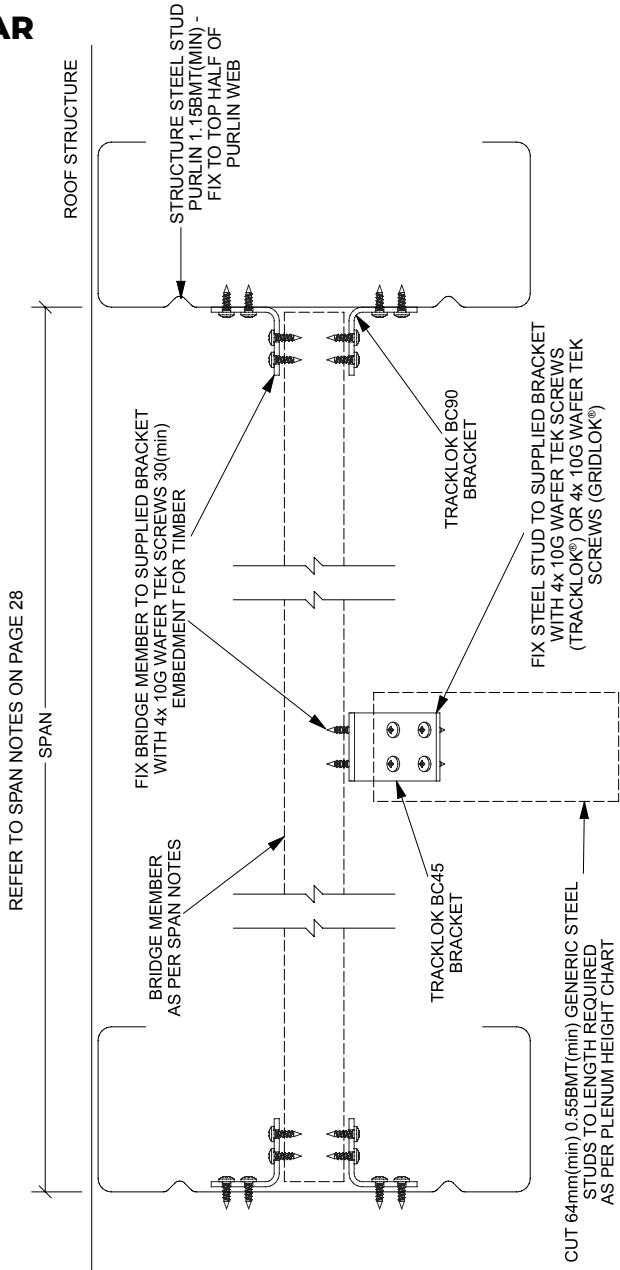

BRIDGING DETAILS & NOTES

PARALLEL & PERPENDICULAR

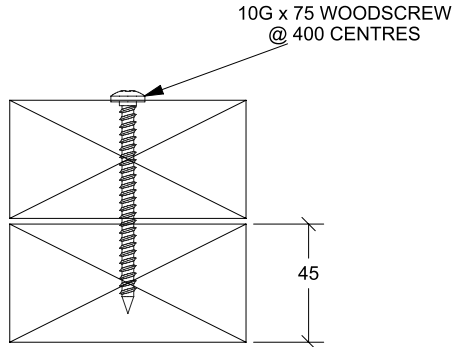

TIMBER DETAIL

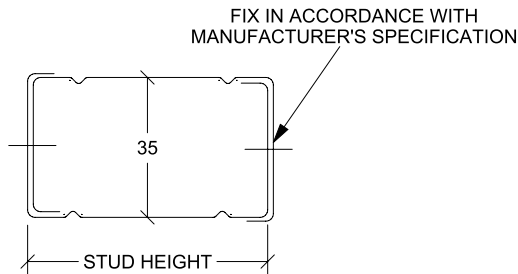

BOXED STUD DETAIL

SPAN NOTES

- Boxed 92mm 0.75BMT(min) generic steel studs maximum permissible span of 950mm
- Boxed 150mm 0.75BMT(min) generic steel studs maximum permissible span of 1500mm
- 90 x 45 SG8 Radiata Pine or Douglas Fir timber maximum permissible span of 850mm
- 2x 70 x 45 SG8 Radiata Pine or Douglas Fir timber maximum permissible span of 1500mm
- 2x 90x 45 SG8 F5 Radiata Pine or Douglas Fir timber maximum permissible span of 2000mm

NOTES

- Structural engineer should confirm loading into the purlins is acceptable
- Bridge detail suitable for TRACKLOK®, TRACKLOK® VERT, GRIDLOK®, (241kg vertical and horizontal)

SERVICE BRIDGE

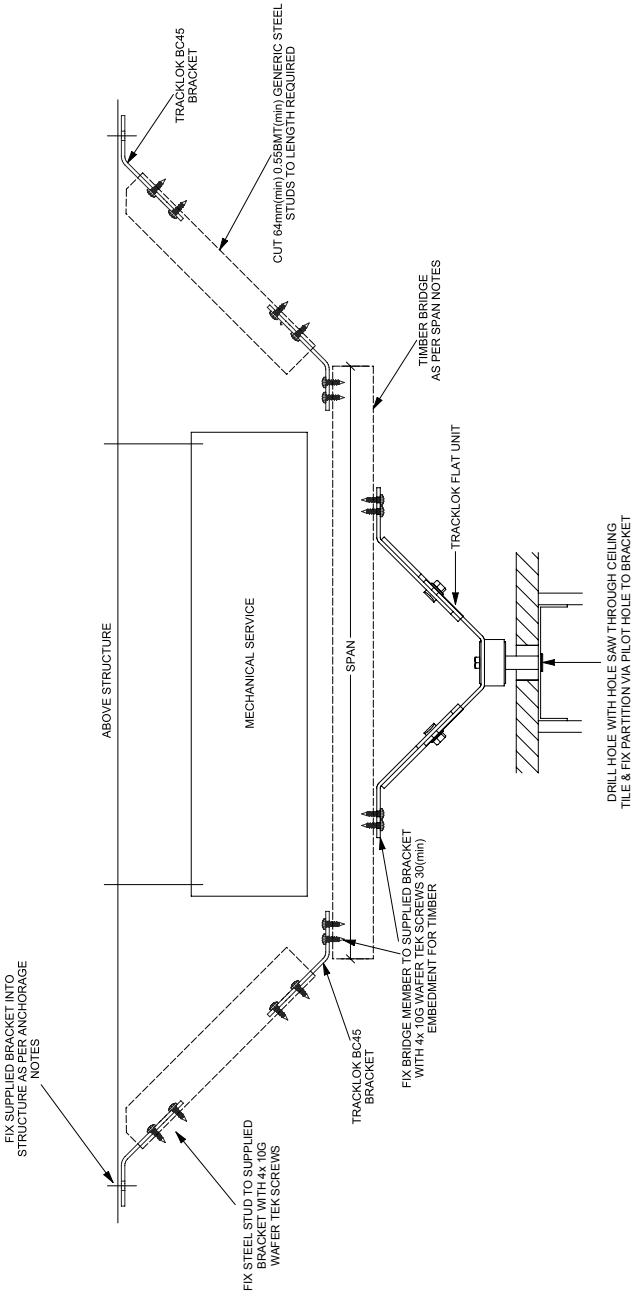

SERVICE BRIDGE DETAILS & NOTES

10G x 75 WOODSCREW
@ 400 CENTRES

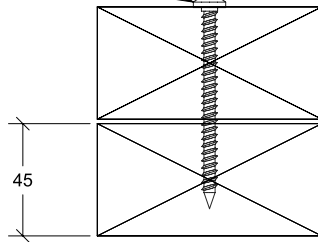

TIMBER DETAIL

FIX IN ACCORDANCE WITH
MANUFACTURER'S SPECIFICATION

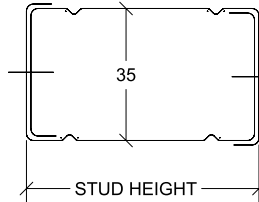

BOXED STUD DETAIL

NOTES

- Structural engineer should confirm loading into the purlins is acceptable
- Bridge detail suitable for TRACKLOK®, (241kg vertical and horizontal)

STRUCTURE ANCHORAGE NOTES

CONCRETE:

- M8 stud anchor 50mm(min) embedment
- M8 screw anchor 50mm(min) embedment

STEEL:

- M8 Cl. 4.8 bolt/nut into 1.15BMT(min)
- 4x 10g wafer tek screws into 0.75BMT(min)

TIMBER:

- M8 x 75mm coach screw full penetration
- M8 Cl. 4.8 bolt/nut with 20mm x 20mm x 1.5mm washer
- 4x 10g x 35mm woodscrews 30mm(min) penetration

SPAN NOTES

- Boxed 92mm 0.75BMT(min) generic steel studs maximum permissible span of 950mm
- Boxed 150mm 0.75BMT(min) generic steel studs maximum permissible span of 1500mm
- 90 x 45 SG8 Radiata Pine or Douglas Fir timber maximum permissible span of 850mm
- 2x 70 x 45 SG8 Radiata Pine or Douglas Fir timber maximum permissible span of 1500mm
- 2x 90x 45 SG8 Radiata Pine or Douglas Fir timber maximum permissible span of 2000mm

BULKHEAD BRACING

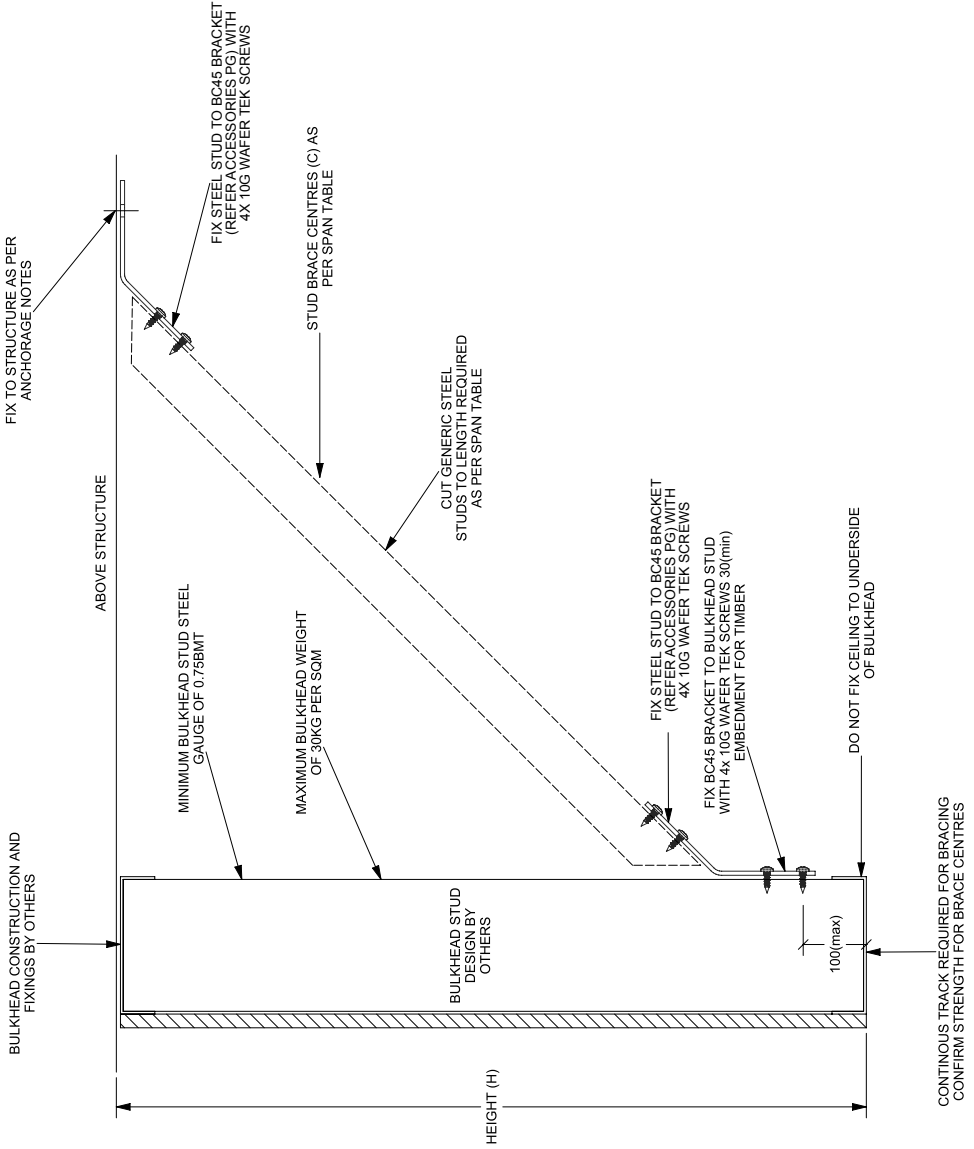

BULKHEAD BRACING NOTES

PERMISSIBLE BRACE CENTRES (C) MM

HEIGHT MM	STEEL STUD BRACE SIZE	
	64MM .55 BMT	92MM .75 BMT
1600	2400	2400
1800	1600	2400
2000	1200	2400
2200	900	1500
2400	700	1200
2600	500	900
2800	400	700
3000	300	600

STRUCTURE ANCHORAGE NOTES

CONCRETE:

- M8 stud anchor 50mm(min) embedment

STEEL:

- M8 Cl. 4.8 bolt/nut into 1.15BMT(min)
- 4x 10g wafer tek screws into 0.75BMT(min)

TIMBER:

- M8 x 75mm coach screw full penetration
- M8 Cl. 4.8 bolt/nut with 20mm x 20mm x 1.5mm washer
- 4x 10g x 35mm woodscrews 30mm(min) penetration

SPAN NOTES

- Bulkhead is to be internal and non-load bearing
- Structural engineer should confirm strength of bulkhead studs and connections
- Bulkhead to be lined at least one side with 10mm(min) plasterboard to transfer shear loading
- Based upon a maximum bulkhead weight of 30kg per square metre
- Do not attach ceiling to underside of bulkhead. Additional weight needs to be considered
- Continuous track required to transfer load between braces. Design to be confirmed by others
- Minimum bulkhead stud steel gauge of 0.75BMT

APPENDIX - TRACKLOK®

OVERVIEW

This report outlines the methods that shall be adopted for Specific Engineering Design (SED) for TRACKLOK® bracing systems for non-load bearing internal walls. Design shall be carried out in accordance with B1/VM1 of the New Zealand Building Code. The partition studs and connections are not considered as part of this scope, however need to be considered within the design.

LOADING METHODOLOGY

Loading Standards

The following standards shall be used to determine the design actions on the systems:

- AS/NZS 1170.0:2002 - Structural Design Actions - General Principles
- AS/NZS 1170.2:2011 - Structural Design Actions - Wind Actions
- NZS 1170.5:2004 - Structural Design Actions - Earthquake Actions

Load combinations shall be applied as per AS/NZS 1170.0. ULS design shall be implemented for the bracing elements, and SLS deflection requirements should be considered for items such as the wall studs and headtrack to limit damage of the wall.

Seismic Action Assumptions

NZS 1170.5 - Section 8 shall be used to determine the horizontal and vertical design actions upon the system. The following assumption should be adopted for bracing design:

- Site Subsoil Class C
- Period, $T < 0.75s$
Ceilings/partitions should be designed for $< 0.75s$ to give the most adverse component spectral shape coefficient $C_i(T_p)$ as per Section 8.4 of NZS 1170.5. Hard to determine the period of a suspended ceiling/partition, so have taken the conservative option.
- Near Fault Factor, $N(T,D) = 1.0$
- Ductility, $\mu = 1.0$

- Part Category P.2/P.3 (ULS Design)

Note: this is for ULS design as per "Loading Methodology" section in manual. $\mu = 1.0$ as connections/buckling is limiting. AS 4600 has a maximum value of 1.25 and we have taken the conservative option of 1.0 as per 8.7.1 of NZS 1170.5 for non-ductile connections.

Wind Action Assumptions

AS/NZS 1170.2 shall be used to determine the horizontal and vertical design actions upon the system. The following should be adopted for internal walls that do not form a permanent seal:

- Net Pressure Coefficient, $C_{fig} = \pm 0.3$
- Dynamic Response Factor, $C_{dyn} = 1.0$
Note: that external walls will have a higher net pressure coefficient and shall be considered as part of specific engineering design.

Live Actions Assumptions

Soft Body Impact as per Table C1 of AS/NZS 1170.0 shall be considered as follows:

- $Q = 0.7kN$

DESIGN METHODOLOGY

Tributary Area

The tributary area method shall be used to determine the bracing demand. The braces are designed to withstand out of plane loads, as shown in Figure 1 below.

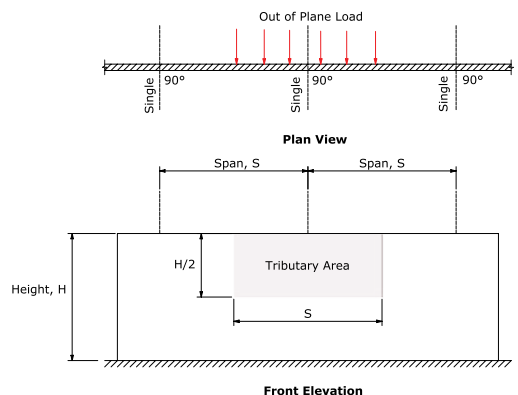

Figure 1 - Tributary area diagram for design

APPENDIX - TRACKLOK®

The following assumptions are used:

- The partition wall is sufficiently supported along the floor track
- The partition wall has sufficient shear resistance in plane
- The headtrack and wall studs have sufficient capacity to transfer load between braces

Brace Demand

The bracing demand shall be within the permissible ratings of each TRACKLOK® component. Specific engineering design around studs and structure fixings are permissible, so long as the demand does not exceed the TRACKLOK® ratings. TRACKLOK® components are rated as shown in Figure 2 below. Bracing angles shall be considered to determine loading in other parts of the design.

Figure 2 (opposite) - Illustration of TRACKLOK® component ratings

TRACKLOK® components have the following ratings:

TRACKLOK®	2.37kN
TRACKLOK® PLUS	2.37kN
TRACKLOK® FLAT	2.37kN
TRACKLOK® VERT	2.37kN
DEFLOK®	2.37kN
DEFLOK® VERT	2.37kN

Table 1 below, shows TRACKLOK® ratings based on plenum height.

DESIGN VERIFICATION

The following standards should be used to validate specific engineering design:

- Steel Studs & Connections: AS/NZS 4600:2005 - Cold-Formed Steel Structure
- Timber Studs & Connections: NZS 3603:1993 - Timber Structures Standard
- Concrete Anchors: NZS 3101:2006 - Concrete Structures Standard

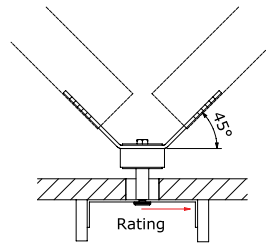

Table 1: Permissible horizontal loads in accordance with AS/NZS 4600

PLENUM HEIGHT MM	64 X 0.55BMT STUDS*	92 X 0.75BMT STUDS*	64 X 0.55BMT BOXED STUDS*	92 X 0.75BMT BOXED STUDS*
0 - 600	250kgf/2.45kN	280kgf/2.75kN	250kgf/2.45kN	280kgf/2.75kN
600 - 1000	250kgf/2.45kN	280kgf/2.75kN	250kgf/2.45kN	280kgf/2.75kN
1000 - 1400	250kgf/2.45kN	280kgf/2.75kN	250kgf/2.45kN	280kgf/2.75kN
1400 - 1800	160kgf/1.57kN	270kgf/2.65kN	250kgf/2.45kN	280kgf/2.75kN
1800 - 2200	110kgf/1.07kN	180kgf/1.77kN	250kgf/2.45kN	280kgf/2.75kN
2200 -2600	80kgf/.78kN	130kgf/1.27kN	250kgf/2.45kN	280kgf/2.75kN
2600 - 3000	60kgf/.58kN	100kgf/.98kN	190kgf/1.86kN	280kgf/2.75kN
3000 - 3500	-	-	140kgf/1.37kN	280kgf/2.75kN
3500 - 4000	-	-	100kgf/.98kN	210kgf/2.05kN

* Stud to TRACKLOK®/DEFLOK® connection to consist of 4/10g tek screws.

NOTE: Tables suitable for brace arm degree range set 40 – 60°. Brace arms set at 30 – 40° range a 30% reduction in stud capacity applies.

APPENDIX - GRIDLOK®

OVERVIEW

This report outlines the methods that shall be adopted for Specific Engineering Design (SED) for seismic bracing using GRIDLOK® for suspended ceilings. Design shall be carried out in accordance with B1/VM1 of the New Zealand Building Code. Vertical loading and specific suspended ceiling system design is not covered within this scope.

LOADING METHODOLOGY

Loading Standards

The following standards shall be used to determine the design actions on the systems:

- NZS 1170.5:2004 - Structural Design Actions - Earthquake Actions
- AS/NZS 1170.2:2011 - Structural Design Actions - Wind Action
- AS/NZS 2785:2020 - Suspended Ceilings - Design and Install

Load combinations shall be applied as per AS/NZS 2785. ULS design shall be implemented for the bracing elements as per Table 8.1 of NZS 1170.

Seismic Action Assumptions

NZS 1170.5 - Section 8 shall be used to determine the horizontal and vertical design actions upon the system. The following assumption should be adopted for bracing design:

- Site Subsoil Class C
- Period, $T < 0.4s$
- Near Fault Factor, $N(T,D) = 1.0$
- Ductility, $\mu = 1.0$
- Part Category P.2/P.3 (ULS Design)

Wind Action Assumptions

Where the ceiling is raking, lateral restraint will be required to resist wind loads. AS/NZS 1170.2 shall be used to determine the horizontal and vertical design actions upon the system. The following should be

adopted for ceilings that do not form a permanent seal:

- Net Pressure Coefficient, $C_{fig} = \pm 0.3$
- Dynamic Response Factor, $C_{dyn} = 1.0$

Note that external ceilings and soffits have a higher net pressure coefficient and shall be considered as part of specific engineering design.

DESIGN METHODOLOGY

Tributary Area

The tributary area method shall be used to determine the bracing demand. The braces are designed to withstand lateral loads, as shown in Figure 1 below. The following assumptions are used:

- A minimum of two braces are used for stability
- All ceiling perimeters are to have a floating connection to allow for inter-story drift
- Maximum ceiling tee lengths to be checked as per manufacturer's requirements
- Vertical suspension as per manufacturer's requirements
- The ceiling behaves as a rigid diaphragm
- Manufacturer seismic requirements are complied with

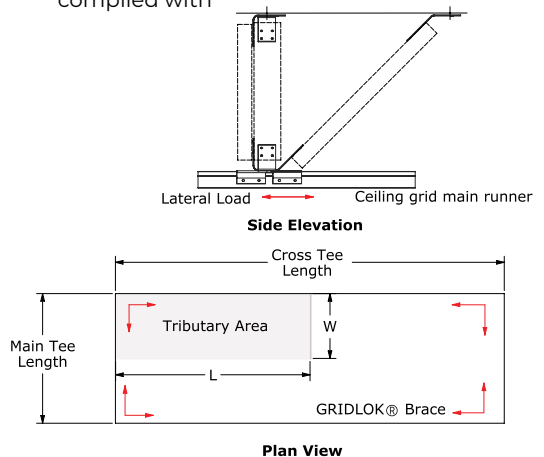

Figure 1 - Tributary area diagram for design

APPENDIX - GRIDLOK®

Brace Demand

The bracing demand shall be within the permissible ratings of each GRIDLOK® component. Specific engineering design around studs and structure fixings are permissible, so long as the demand does not exceed the maximum GRIDLOK® rating of 280kgf.

Tributary Area Demand < GRIDLOK® Capacity

Table 1 below, shows GRIDLOK® ratings based on plenum height.

DESIGN VERIFICATION

The following standards should be used to validate specific engineering design:

- Steel Studs & Connections: AS/NZS 4600:2005 - Cold-Formed Steel Structures
- Timber Studs & Connections: NZS 3603:1993 - Timber Structures Standard
- Concrete Anchors: NZS 3101:2006 - Concrete Structures Standard

Table 1: Permissible horizontal loads in accordance with AS/NZS 4600

PLENUM HEIGHT MM	64 X 0.55BMT STUDS*	92 X 0.75BMT STUDS*	64 X 0.55BMT BOXED STUDS*	92 X 0.75BMT BOXED STUDS*
0 - 600	250kgf/2.45kN	280kgf/2.75kN	250kgf/2.45kN	280kgf/2.75kN
600 - 1000	250kgf/2.45kN	280kgf/2.75kN	250kgf/2.45kN	280kgf/2.75kN
1000 - 1400	250kgf/2.45kN	280kgf/2.75kN	250kgf/2.45kN	280kgf/2.75kN
1400 - 1800	160kgf/1.57kN	270kgf/2.65kN	250kgf/2.45kN	280kgf/2.75kN
1800 - 2200	110kgf/1.07kN	180kgf/1.77kN	250kgf/2.45kN	280kgf/2.75kN
2200 -2600	80kgf/.78kN	130kgf/1.27kN	250kgf/2.45kN	280kgf/2.75kN
2600 - 3000	60kgf/.58kN	100kgf/.98kN	190kgf/1.86kN	280kgf/2.75kN
3000 - 3500	-	-	140kgf/1.37kN	280kgf/2.75kN
3500 - 4000	-	-	100kgf/.98kN	210kgf/2.05kN

* Stud to GRIDLOK® connection to consist of 4/10g tek screws.

NOTE: Tables suitable for brace arm degree range set 40 – 60°. Brace arms set at 30 – 40° range a 30% reduction in stud capacity applies.

TERMS & CONDITIONS

TRACKLOK® INSTALLATION/

Must be installed in accordance with manufacturers specification and within the parameters of AS/NZS1170.5. Install sheets for TRACKLOK® | TRACKLOK® PLUS | TRACKLOK® VERT | TRACKLOK® VERT PLUS | TRACKLOK® FLAT | TRACKLOK® FLAT PLUS are available online at www.tracklok.com. Partition walls must be installed as per manufacturers recommendation. Create a minimum clearance of 10mm from unit to ceiling tile and/or grid. Installation at centres and configurations as referenced in set out sheets. Set out sheets cover standard partitioning requirements; construction outside of available set out sheet information will require consultation and approval. Approved seismic fixings to be used for attachment to structure over. Architect and/or Structural Engineer and relevant regulatory bodies must approve variations of installation. Bracing material must be fixed with 10-gauge drill point wafer head tek screws. Steel bracing material must be as per plenum height charts or as designed by engineer. Although all aluminium head track with a material thickness of 1.3mm – 1.8mm is acceptable for use, we do not take responsibility or liability for performance of, or installation of partition or glazing head track. Use of .55BMT steel track, as head section is not permitted under this specification. Installation is required 100mm – 300mm from the end of blade walls. T section walls are deemed self-supporting requiring unit to be placed at distance specified by the set out sheets. The unit must not be deformed or altered in any way. Ceiling void heights over 2.0 meters require stud bracing to be boxed. Continuous head track over door requires unit to be installed on latch side, broken head track over door requires units to be installed on latch side and hinge side. Tenancy changes requiring walls to be moved require new units to be installed.

LIMITATIONS

For interior application only. Designed to secure standard steel, aluminium and timber partition walls and glazed walls. Not applicable for supporting walls constructed from concrete, tilt slab or block. Structural engineer and regulatory body must seismically approve configurations outside of specifications. The unit and or bracing material must not be used as an anchor point or fixing point by associated trades. Use of this product does not increase the seismic load capacity of installed ceiling grid.

GRIDLOK® INSTALLATION

Must be installed in accordance with manufacturers specification and within the parameters of AS/NZS1170.5 AS/NZS4219 AS/NZS2785. Install sheets are available online and in every box of GRIDLOK®. Ceilings must be installed as per manufacturers recommendation. Installation at centres and configurations as referenced by ceiling designers, ceiling manufacturers recommendations given GRIDLOK® capacity. Construction outside of available information will require consultation and approval. Approved seismic fixings to be used for attachment to structure over. Architect and / or structural engineer plus relevant regulatory bodies must approve variations of installation. Bracing material must be fixed with 10-gauge drill point wafer head tek screws. Steel bracing material must be 64mm .55 BMT, .75 BMT or 1.15 BMT or 92mm .55 BMT, .75 BMT or 1.15 BMT. All GRIDLOK® units and bracing must be checked after seismic event for signs

of wear. GRIDLOK® is not intended to replace ceiling suspension wires, which must be installed as per manufacturers specification. Although all ceiling grid is acceptable for use we do not take responsibility or liability for performance of, or installation of ceiling grid. The unit must not be deformed or altered in any way. Tenancy changes requiring new ceiling installation requires new GRIDLOK® units to be installed.

LIMITATIONS

For interior application only. Structural engineer and regulatory body must seismically approve configurations outside of specifications. The unit and / or bracing material must not be used as an anchor point or fixing point by associated trades.

DEFLOK® INSTALLATION

Must be installed in accordance with manufacturers specification and within the parameters of AS/NZS1170. Install instructions for DEFLOK® | DEFLOK® VERT are available online at www.tracklok.com. Partition walls must be installed as per manufacturers recommendation. Create a minimum clearance of 10mm from unit to ceiling tile and/or grid. Installation at centres and configurations as referenced in plan mark out provided by plans@tracklok.com. Reflected Ceiling Plan markup covers standard partitioning requirements; construction outside of these parameters may need additional information and/or will require consultation and approval. Approved seismic fixings to be used for attachment to structure over. Architect and / or Structural engineer and relevant regulatory bodies must approve variations of installation. Bracing material must be fixed with 10-gauge drill point wafer head tech screws. Steel bracing material must be 64mm .75 BMT or 92mm .75 BMT. Although all aluminium head track with a material thickness of 1.3mm – 1.8mm is acceptable for use we do not take responsibility or liability for performance of or installation of partition or glazing head track. Use of .55BMT steel track, as head section, is not permitted under this specification. Installation is required 100mm – 300mm from the end of blade walls. T intersection walls are deemed self-supporting requiring unit to be placed at a minimum of 1500mm. The unit must not be deformed or altered in any way. Ceiling void heights over 3150mm require stud bracing to be boxed. Continuous head track over door requires unit to be installed on latch side, broken head track over door requires units to be installed on latch side and hinge side. Tenancy changes requiring walls to be moved require new units to be installed.

LIMITATIONS

For interior application only. Designed to secure standard steel, aluminum and timber partition walls and glazed walls. Not applicable for supporting walls constructed from concrete, tilt slab or block. Structural engineer and regulatory body must approve configurations outside of specifications. The unit and or bracing material must not be used as an anchor point or fixing point by associated trades. Use of this product does not increase the seismic load capacity of installed ceiling grid, unless otherwise stated.

NOTICE

We shall not be liable for incidental and consequential damages, directly or indirectly sustained, nor for any loss caused by application of these goods not in accordance with current printed instructions or for other than intended use. Our liability is expressly limited to replacement of defective goods. Any claim shall be deemed waived unless made in writing to us within thirty (30) days from the date it was or reasonably should have been discovered.

The information presented is correct to the best of our knowledge at the date of issuance. Because codes continue to evolve, check with a local official prior to designing and installing. Other restrictions and exemptions may apply.

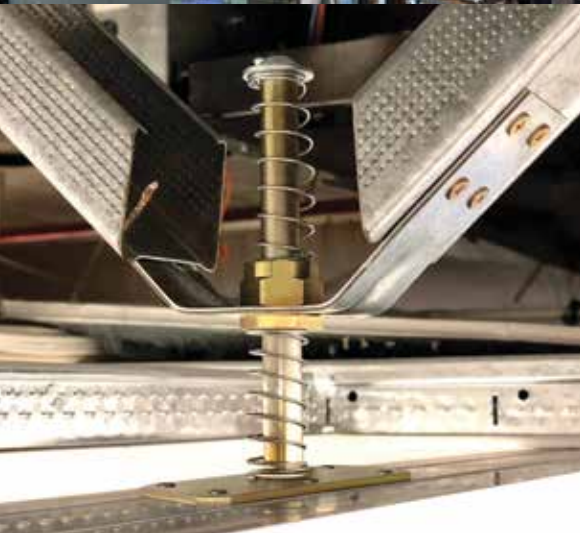

**PLAN MARKUP
& TECH SUPPORT**

Ph +64 21 170 8734
plans@tracklok.com

ORDERS & LOGISTICS

Ph +64 21 645 174
orders@tracklok.com

SALES & INFO

Ph +64 21 152 9136
info@tracklok.com

TRACKLOK Ltd

PO Box 31270, Milford, Auckland 0620

tracklok.com