

ROOF PITCH $\geq 10^\circ$
LOW / MEDIUM / HIGH WIND ZONE

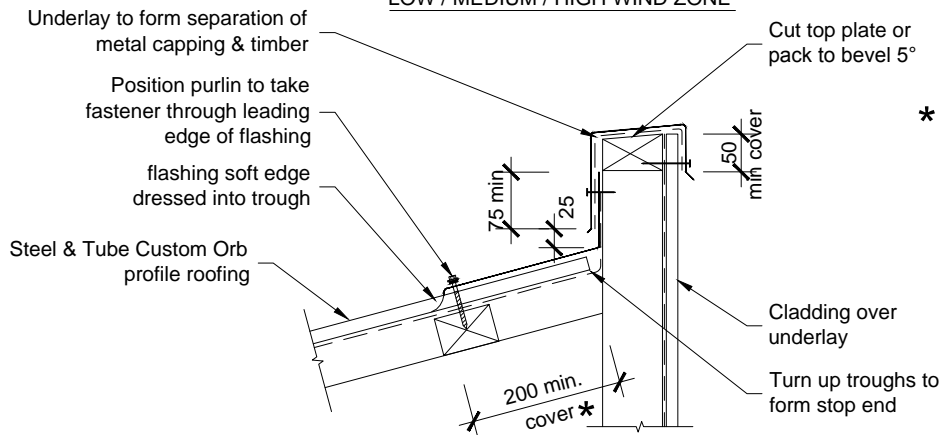

* Alternatively 130 cover with addition of profiled foam sealer above purlin line

ROOF PITCH $< 10^\circ$
LOW / MEDIUM / HIGH WIND ZONE

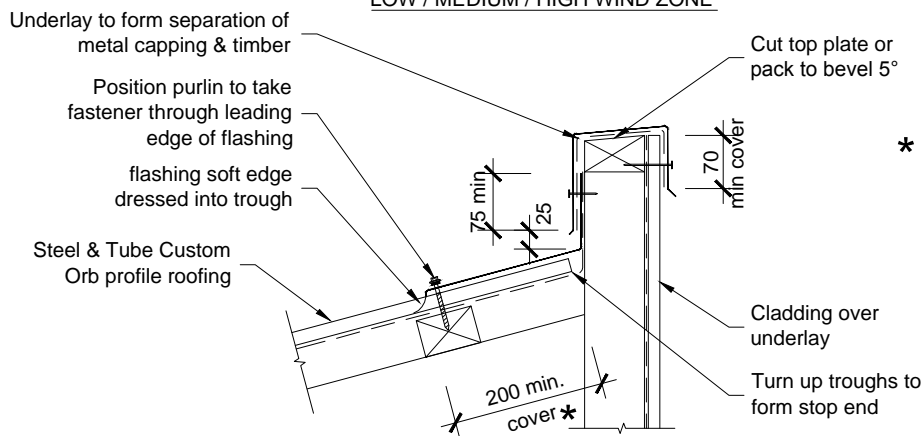

* Alternatively 130 cover with addition of profiled foam sealer above purlin line

ALL PITCHES
VERY HIGH WIND ZONE

corb_custom_orb-parapet

Custom Orb Head Parapet Flashing
Cross Section

All dimensions in millimetres
Scale 1:10
16/01/12